



BHW TECHNOLOGIES



Advanced RF IC, Front-End Module, RF Active integrated Antenna (RFAiA™) and Wireless Sub-System Solutions

BHW AppNote #027

**Coin-Cell and Batteryless 1km Long Range NanoBeacon
with BHWR250A AiA and Energy Harvesting**

Rev. 2.2

www.bhw-tech.com

Coin-Cell/Batteryless Long Range BLE Beacon Solution



Long Range NanoBeacon
Using CR1225/CR1632/CR2032

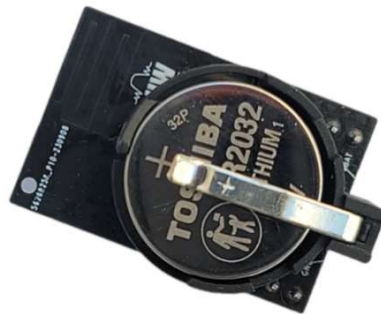
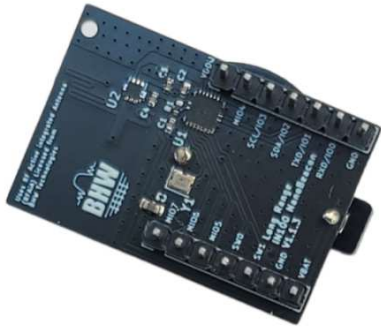

Batteryless LR NanoBeacon
Using Energy Harvesting



Features & Benefits:

- Industry's First Km/Mile Long Range BLE Beacon with Standard 1Mbps Data Rate Based on Small-Size Coin Cells or Energy Harvesting
- Compact 2-Layer FR4 Design: 22.5x33.5x0.8mm with Battery Holder
- Extremely Simple and Low-Cost R-BOM: 1 Crystal, 5 Capacitors, 2 Resistors, Zero Inductors
- Ultra-Low Power Consumption: ~33mA Peak Tx Current is ~1/3 of Typical 20dBm Class-1 PA Alone
- Support Wide Operating Voltage Range (1.5~3.6V) to Maximize Battery Life or Simplify Requirements and Cost of PMICs
- At ~14 nAh or ~50 uC Charge per Beacon Event, it is Possible to Achieve Multi-Year Battery Life with Tiny Coin Cells like CR1225, CR1632 and CR2032, without Compromise in Long-Range Performance
- **The Demonstrated Performance of IN100 SoC & BHWR250A AiA Integration Represents a New Category of 2.4GHz Radio: Comparable or Longer Range than BLE Class-1 but Consuming Only a Fraction of the Power. This Paves the Way towards Prolific Use of Small Coin Cells (or Completely Battery-Free) in IoT Sensor Designs even with Highly Demanding Range Requirements, which was Impossible until Now**



Use Case #1

Long Range BLE NanoBeacon Using Coin-Cell Battery

Coin-Cell Long Range BLE Beacon EVB



Front-Side PCB View, V1.1.3

U1: InPlay IN100 SoC 3x3mm QFN

U2: BHWM253 PA/SW FEM 1.5x1.5mm DFN

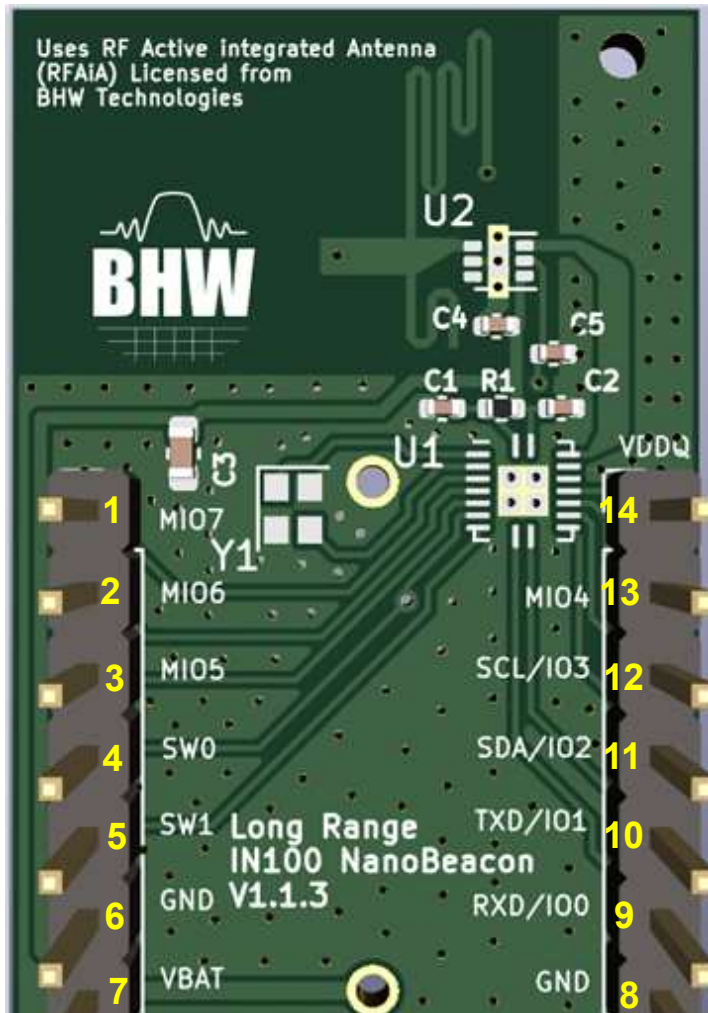

Back-Side PCB View, V1.1.3

Center: CR1225/1632/2032 Battery Holder

Top-Right: Slot Antenna of BHWR250A

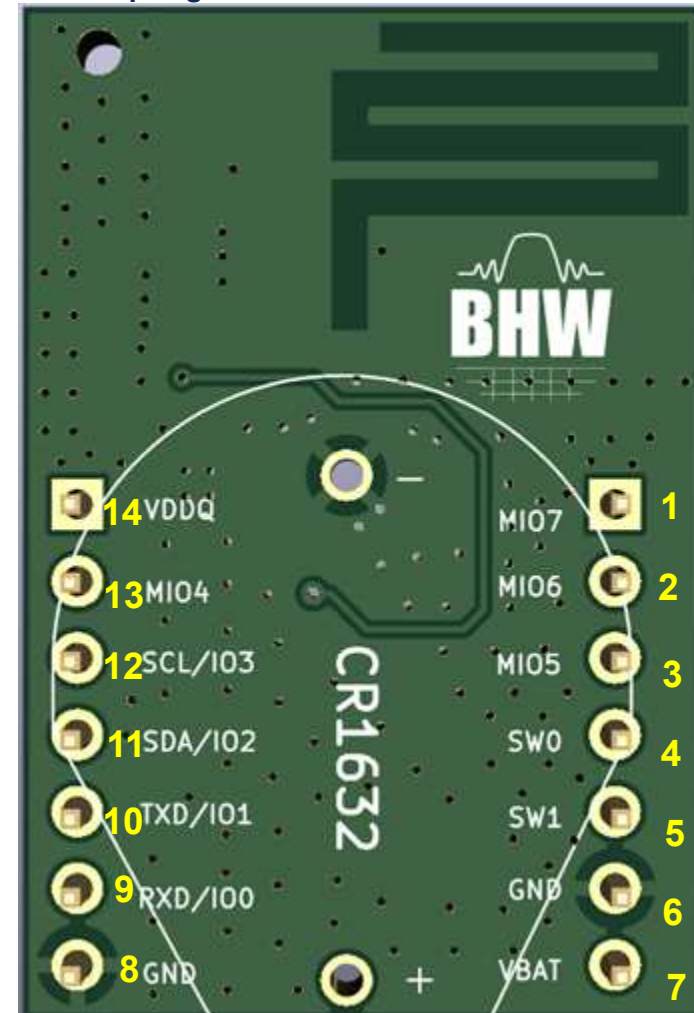

-Battery holder pitch is 16.66mm for CR1632, or CR2032 with minor pitch adjustment. Alternatively a CR1220/CR1225 holder can be soldered directly to PCB on the back side. Use VBAT (Pin 7) for other options of power supply.

-Refer to Page 27 for download of Gerber files. PCB V2.1.1 is an expanded version of V1.1.3 supporting both coin-cell and energy harvesting.

Coin-Cell Long Range BLE Beacon Schematic



Reference Schematic and Nominal BOM, Rev. 1.1.3

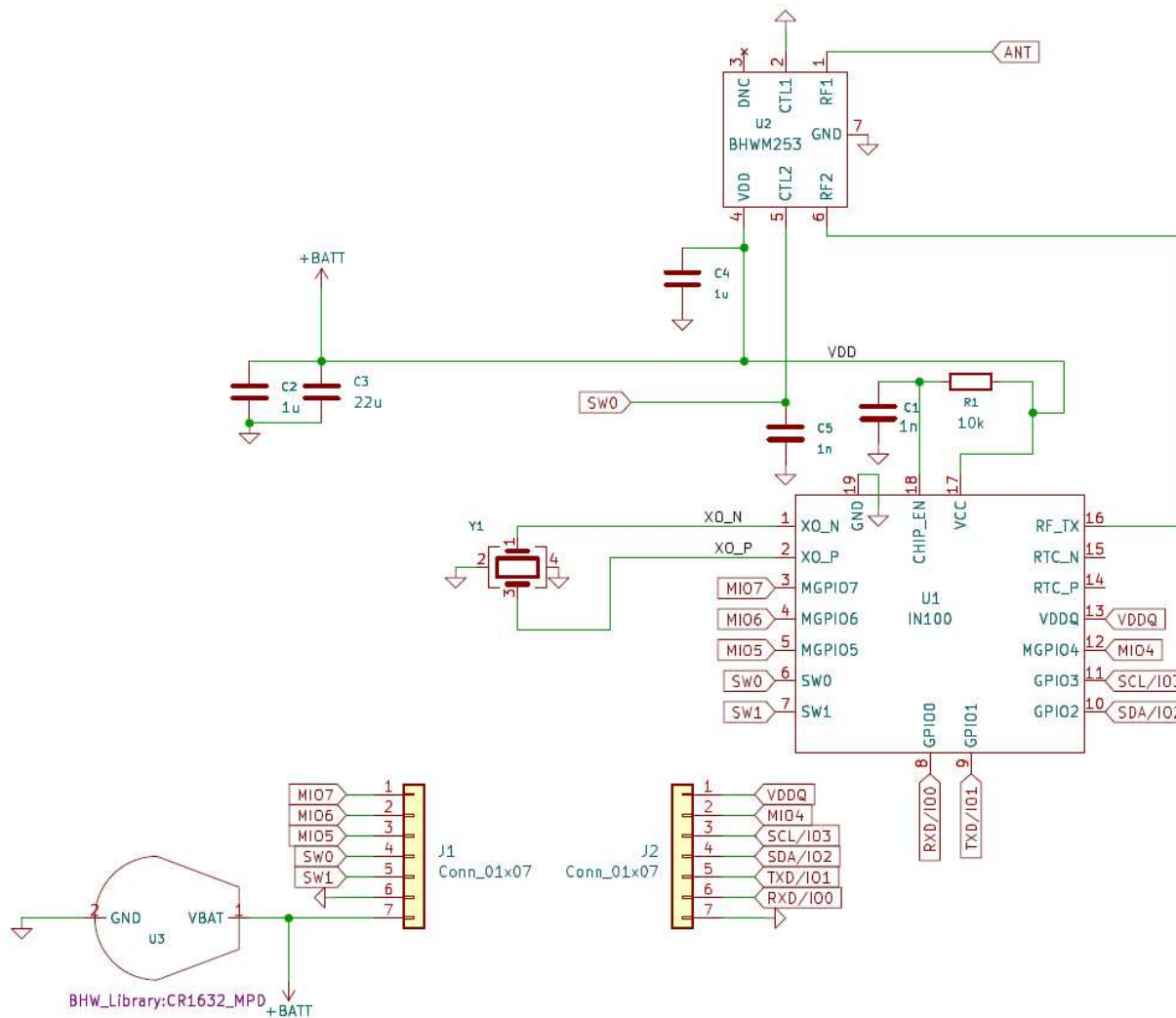

Nominal BOM:

C1=C5=1nF
C2=C4=1uF
C3*=22uF
R1=10 Kohm

U1: IN100 3x3mm QFN-18
U2: BHWM253 1.5x1.5mm DFN-6
U3: Battery CR1632 Minimum
Y1: 26MHz Crystal
(See IN100 Datasheet for AVL of Y1)

*Note: C3 values between 10uF to ~100uF can be used for different types of coin-cell batteries. If available for space and cost, larger-value capacitors are recommended for smaller-size batteries, such as CR1225.

Long Range BLE Beacon with BHWM253 as PA



Measured S-Parameter of BHWM253 Used as PA

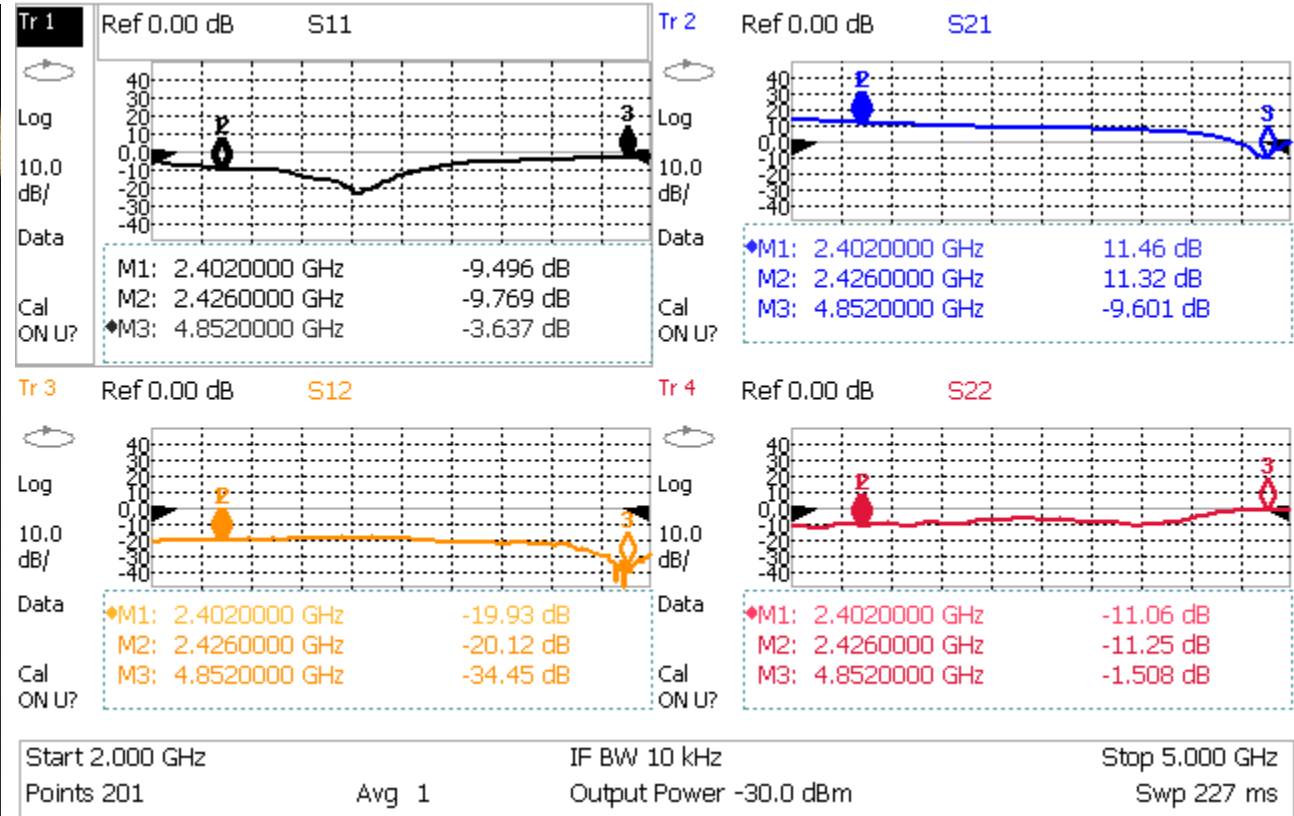
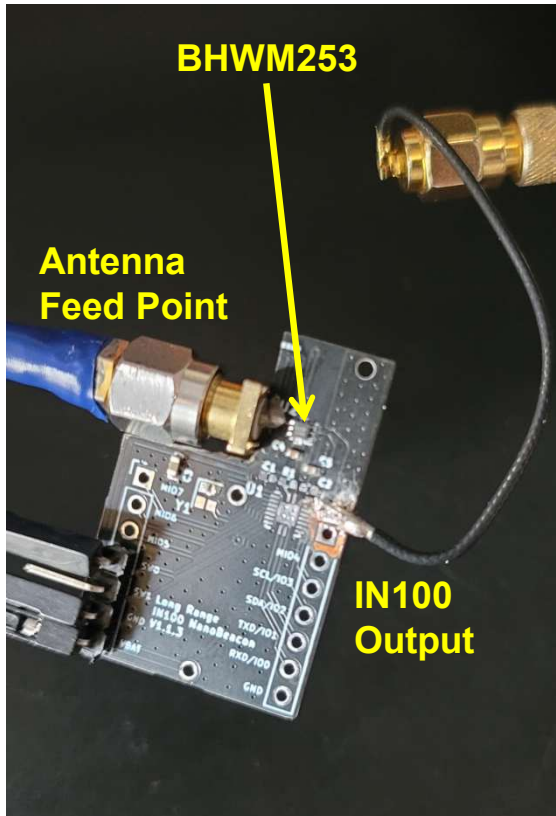

Notes:

- 1) Tested at Vbat=3.3V. BHWM253 configured for PA operation at CTL1=0 (GND), CTL2=3.3V.
- 2) Measurement taken from output of IN100 to antenna feed point.
- 3) Measured data include insertion losses of IPX cable and SMA connectors/adapters.
- 4) Refer to Appendix 2 for further details of BHWM253.

Integrated Antenna for Long Range BLE Beacon



Measured VSWR of Slot Antenna of BHWR250A AiA

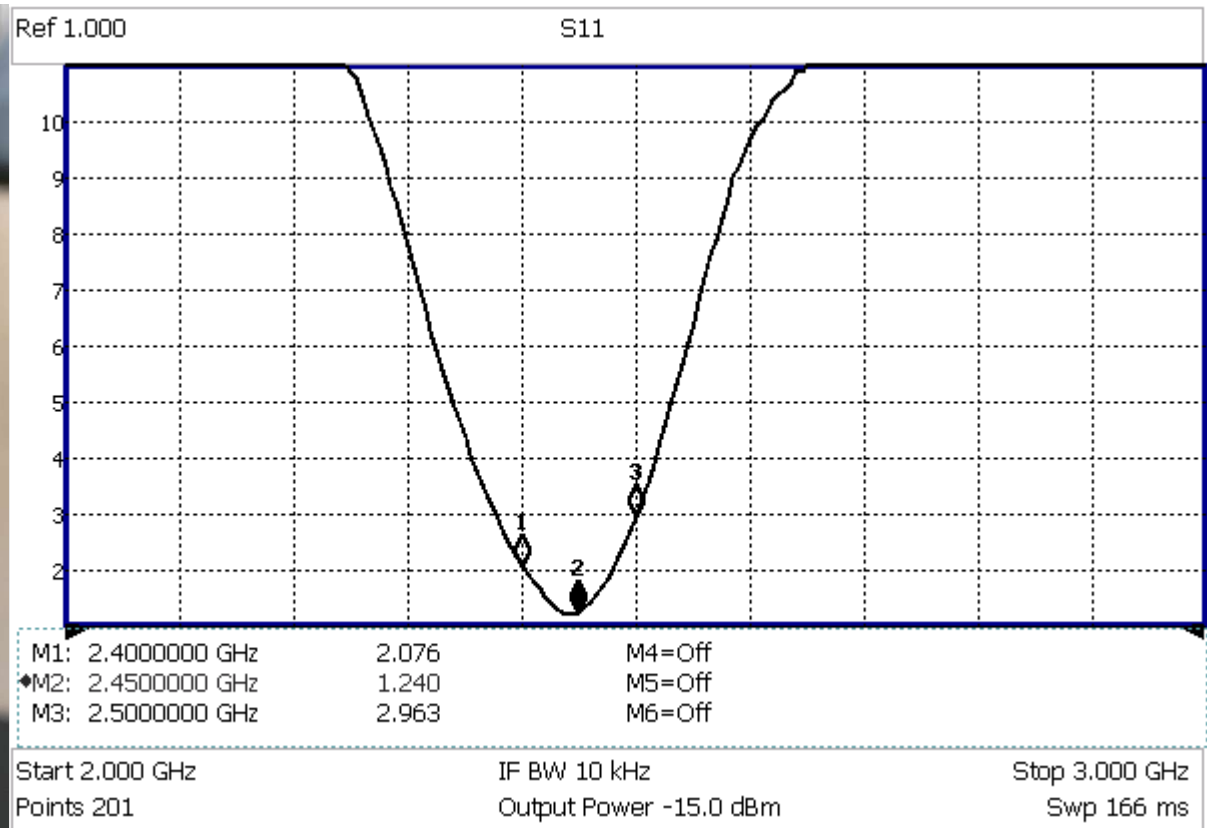
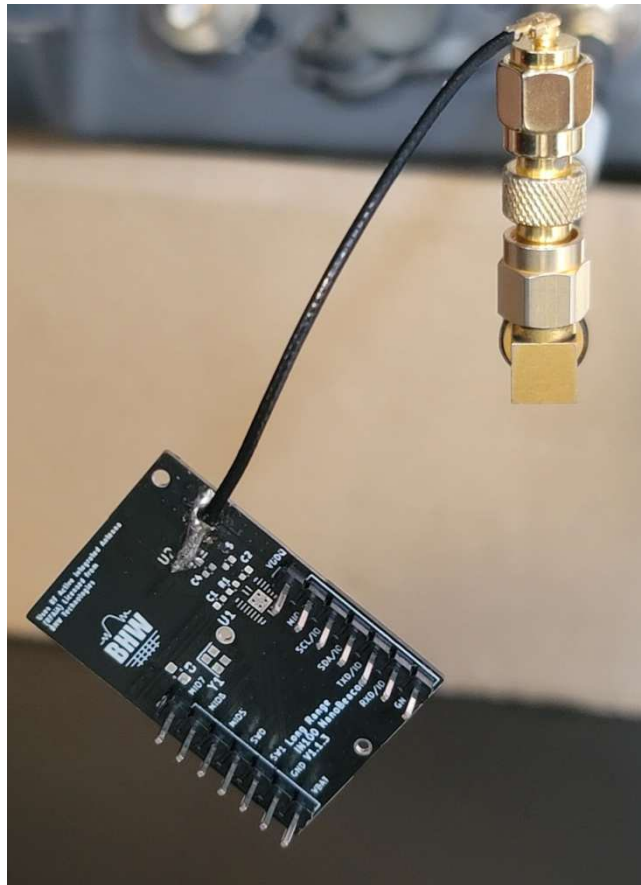

Notes:

- 1) Antenna VSWR is stable when measured with or without pin headers, as well as when mounted on a breadboard.
- 2) Refer to Appendix 1 for further details of BHWR250A AiA.

Integrated Antenna for Long Range BLE Beacon



VSWR Stability of Slot Antenna of BHWR250A AiA

Antenna at Center of Breadboard

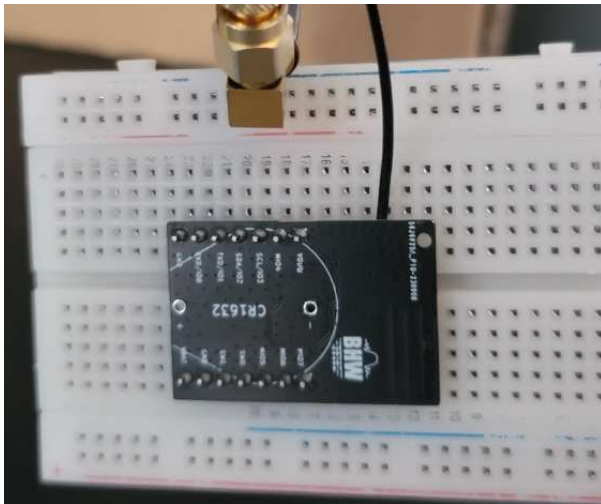

Antenna at Edge of Breadboard

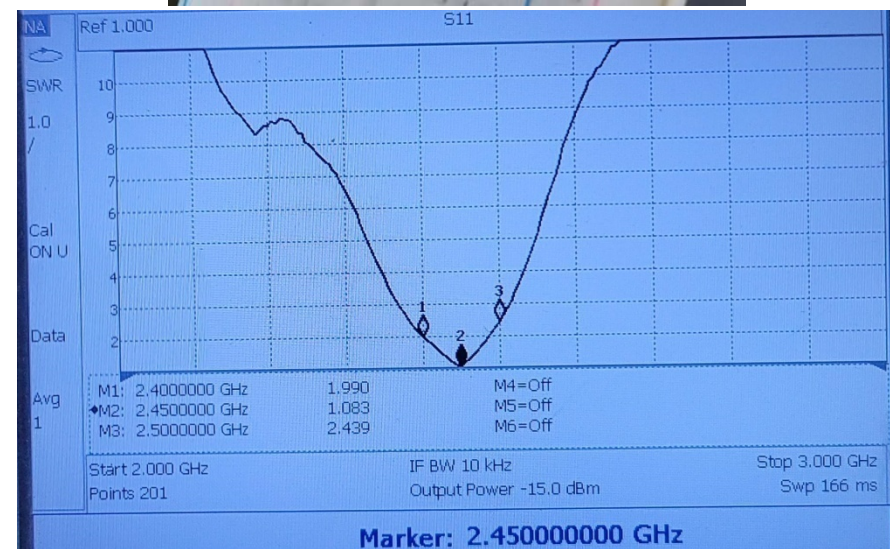
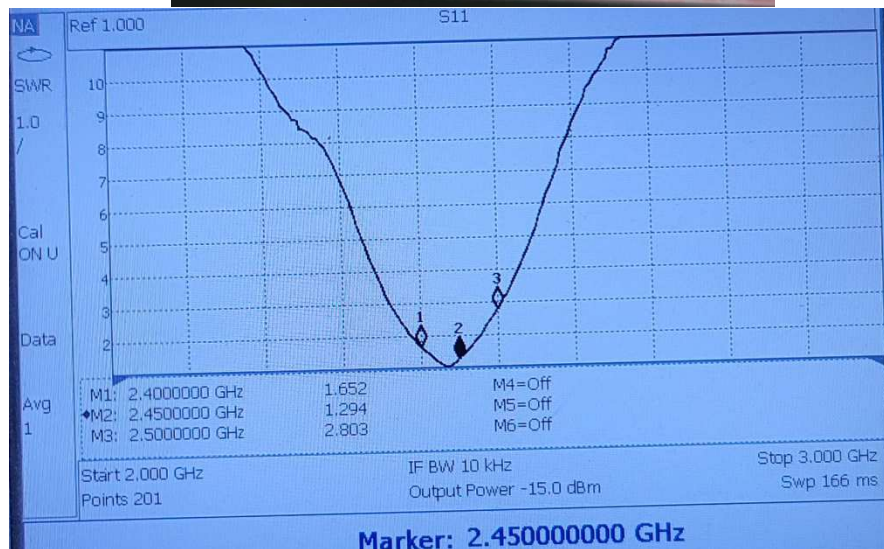

Note: Antenna VSWR varies only slightly when the NanoBeacon board with pin headers is mounted on a typical breadboard, at the center or towards the edge.

Long Range BLE Beacon: Conducted Power Test



Conducted Power Measurement at Antenna Feed Point

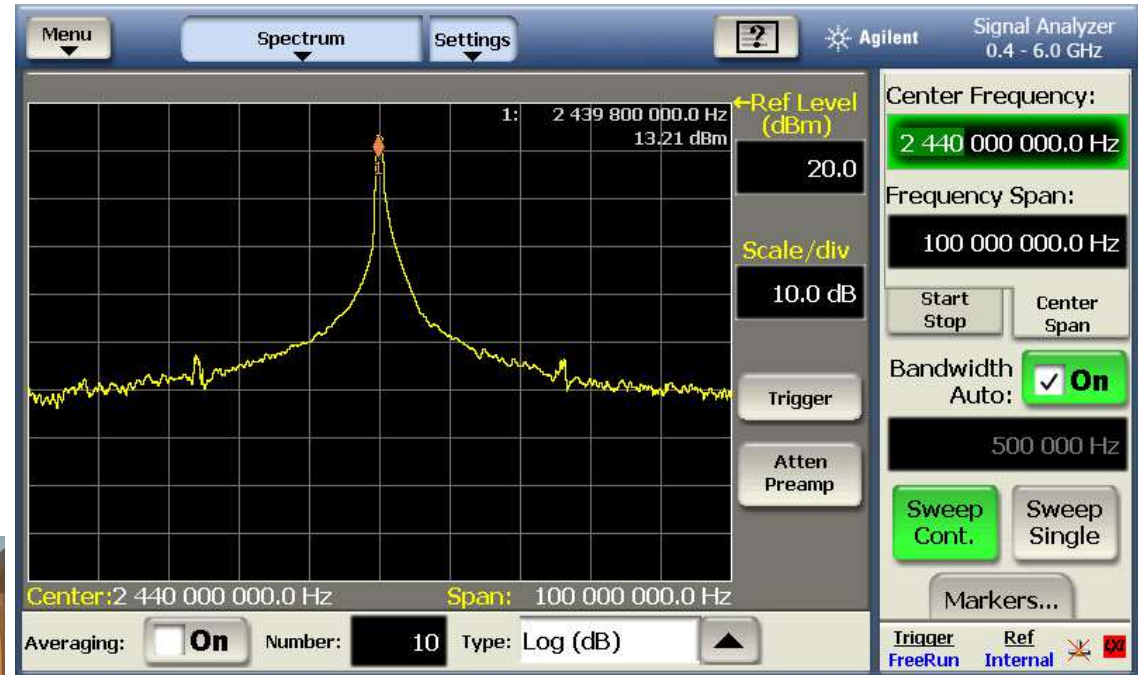
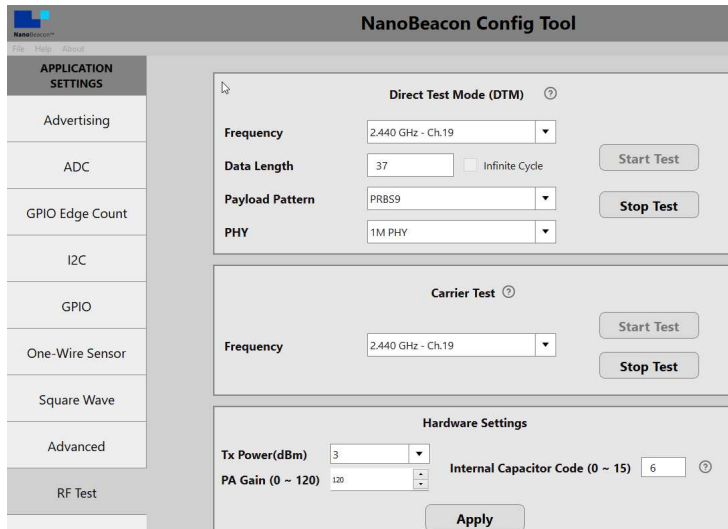

Notes:

- 1) Tested with Direct Test Mode (DTM) inside the NanoBeacon Config Tool. Payload is 31 bytes for the DUT.
- 2) Jumper connection of SW1/SW0 to enable PA.
- 3) IN100 Tx Power was backed off from 5dBm Max to 3dBm to reduce overall current consumption
- 4) Measured Tx power at BHW253 output (antenna feed) was ~13dBm at mid-band (2440MHz) with 3dBm drive level
- 5) Total current is ~26mA at Vdd=3.3V during DTM test with modulated signal. Total current is estimated to be ~35mA for CW.
- 6) Current consumption can be reduced slightly by increasing bias resistor R2 (Default is 0-Ohm) for BHW253
- 7) Tx power can be increased slightly with higher driver power (e.g. 4~5dBm), or using higher Vdd (up to 4.2V Max)
- 8) Tx power can be lowered slightly by backing off IN100 output level, to further reduce power consumption
- 9) Refer to Appendix 2 for further details of BHW253

Coin-Cell Long Range BLE Beacon Power Profile



Using SW0 for BHWM253 PA Enable

Example SW0 Waveform
Advertising Interval 5 sec



Example SW0 Waveform
SW0 ON Time ~1.8ms

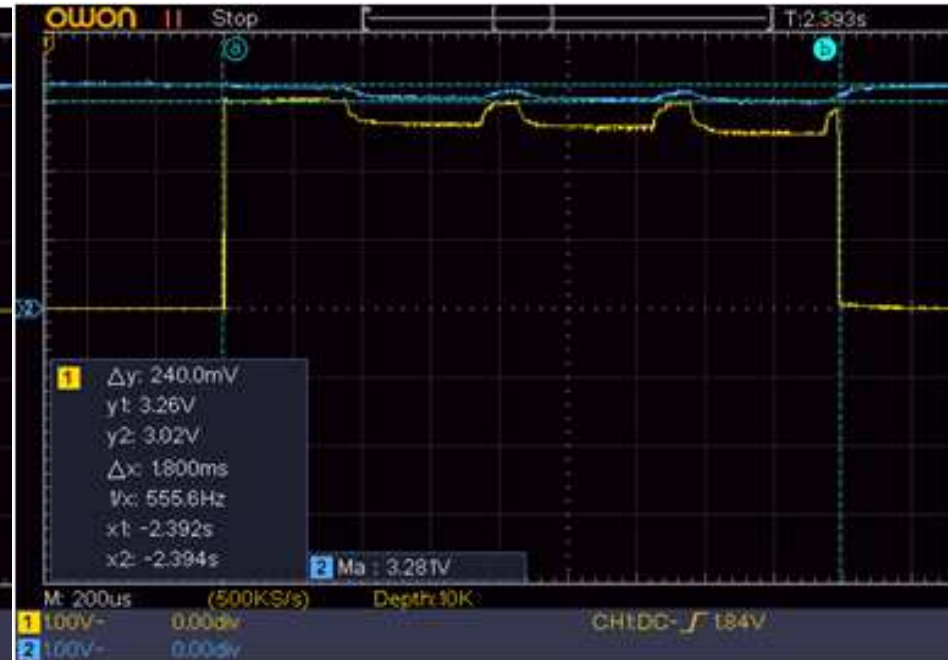

Notes:

- 1) Tested on an EVB powered by CR2032 coin cell battery with $V_{bat} \sim 3.26V$.
- 2) OWON SDS1022 DSO was used to capture voltage waveforms of V_{bat} (Blue) and SW0 (Yellow).
- 3) Measured Tx duration for the advertising event is $\sim 1.8ms$ for the configuration of this test.
- 4) There is a slight drop in V_{bat} voltage during packet transmit of the three advertising channels. This is mainly caused by the peak current supply limitations of small-size coin-cell batteries. Also, increasing the V_{bat} capacitor C3 to a larger capacitance value (e.g. from 10uF to 22~470uF) should help reduce the voltage drop slightly, if size and cost allows.

Courtesy of InPlay Inc. for NanoBeacon power profile configuration and measurement.

Coin-Cell Long Range BLE Beacon Current Test



Peak Current Measurement & Battery Life Estimation

Channel 37
Peak Current ~31.2mA

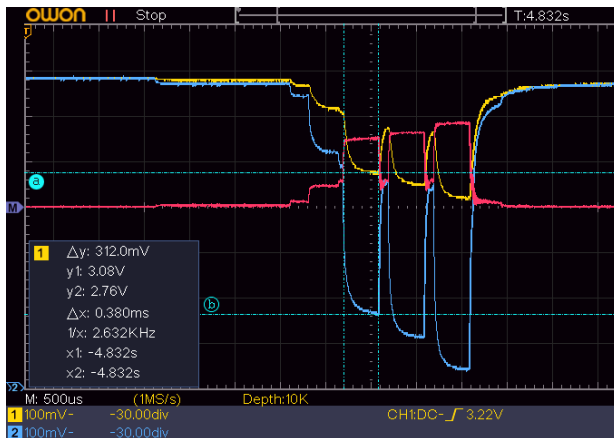

Channel 38
Peak Current ~33.8mA

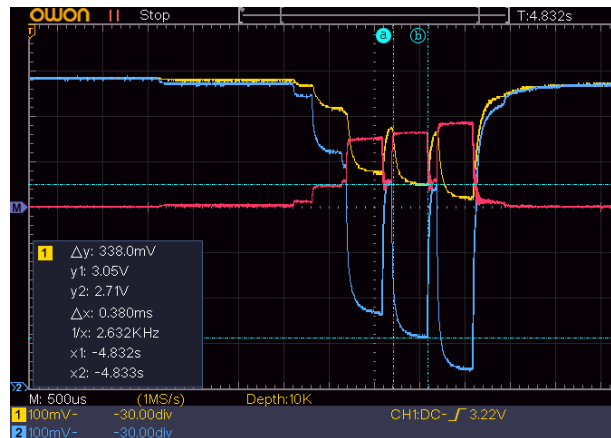

Channel 39
Peak Current ~37.4mA

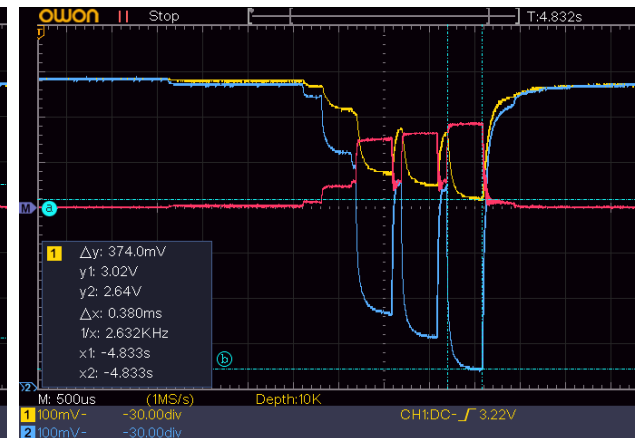

Notes:

- 1) Tested on a CR2032-operated EVB with 10-ohm serial resistor inserted to Vbat line after C3=10uF.
- 2) OWON SDS1022 DSO was used to capture voltage waveforms before (Yellow) and after (Blue) the 10-ohm resistor.
- 3) Instantaneous current (Red) is voltage drop across the serial resistor divided by 10-ohm.
- 4) Measured Tx duration for the entire advertising event is ~1.8ms, as set by SW0 in the previous page.
- 5) Maximum peak current for the three advertising channels range from 31~37mA, consistent with expectation from DTM measurement results using the InPlay NanoBeacon Config Tool. BLE payload is 31 bytes for the DUT.
- 6) Estimated power consumption during the entire advertising event is approximately 49 mA*ms, or 13.6 nAh.
- 7) As reference, a Tier-1 competitor SoC consumes 7.7nAh for the same triple BLE advertisement (27.67uA average current over 1000ms Adv. Interval), roughly half the power consumption, but at 0dBm Tx power and with 14 bytes payload only.
- 8) Sleep Current of the beacon was measured at 963nA(Courtesy of InPlay Inc.), in line with specs of IN100 SoC and BHW M253 PA, which is equivalent to power consumption of 8436 uAh for one year.
- 9) Assuming the use of CR2032 battery with nominal capacity of 225 mAh, useable power for advertising events is approximately 216.6 mAh after considering sleep mode current.
- 10) Using larger-size coin cells such as CR2450 (620 mAh) and longer Advertising Intervals (e.g. 10 sec, 1 min) will allow multiple years (e.g. >5 yrs) of operating lifetime, even after battery leakage, sensor power consumption and other factors are considered. See next page for details.

Coin-Cell Long Range BLE Beacon Stress Test



Accelerated Stress Test & Battery Life Estimate for Various Coin Cells

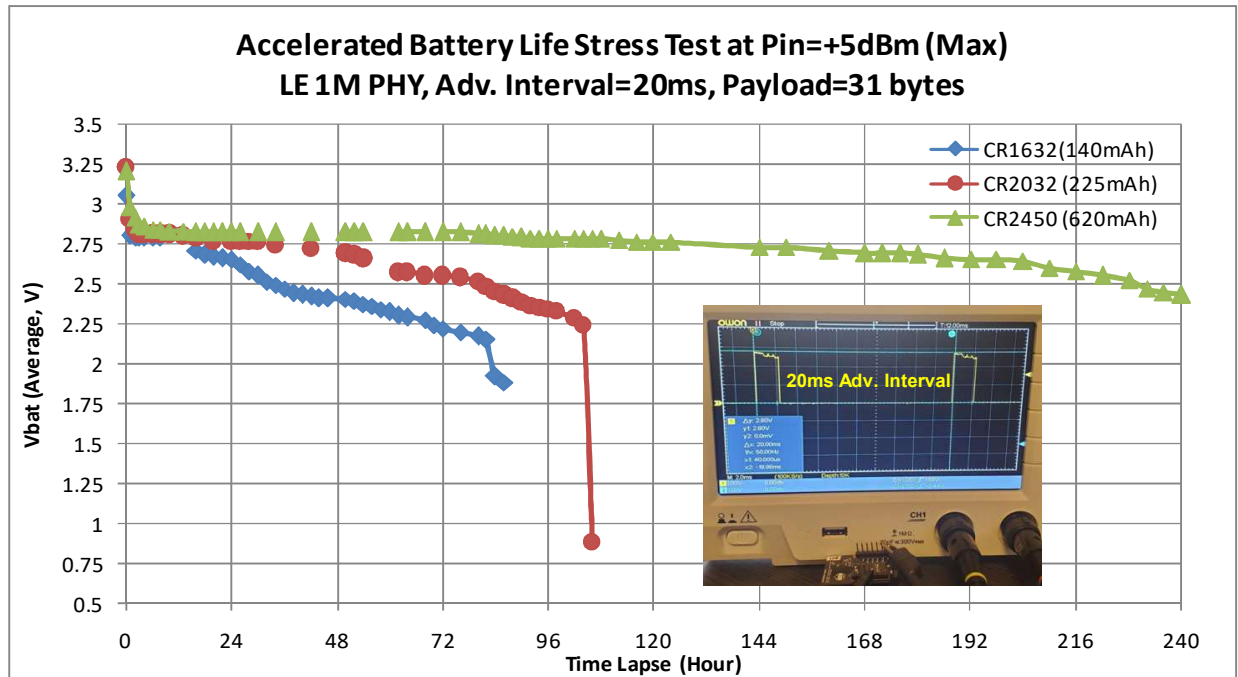

1km Long Range NanoBeacon Battery Life Estimate:

Battery Type	Battery Size	Nominal Capacity (mAh)	Estimated Battery Life (Years)		
			Assumption: LE 1M PHY, Payload=31 bytes, Pin=+3dBm to PA, For NanoBeacon Only		
			Adv. Interval (ms) = 1000	Adv. Interval (ms) = 3000	Adv. Interval (ms) = 10000
CR1225	12.5x2.5mm	50	0.1	0.3	1.0
CR1632	16x3.2mm	140	0.3	0.9	2.7
CR2032	20x3.2mm	225	0.5	1.5	4.4
CR2450	24.5x5mm	620	1.4	4.1	12.1
CR2477	24x7.7mm	1000	2.3	6.6	19.5

Notes:

- 1) Current consumption for each Advertising Cycle is sum of that during Tx Active and Sleep Mode
- 2) Current*Duration for Tx Active for Pin = +3dBm (Tx power = +13dBm at antenna) was measured at 49 mA*ms
- 3) Current*Duration for Sleep Mode equals 0.000963mA*(Adv. Interval in ms)
- 4) Total current consumption (in uAh) for each Advertising Cycle including Sleep Time is (49+0.000963*(Adv. Interval))/3600
- 5) The estimated battery life is for IN100 SoC and BHW253 PA only and does not include power for other components (e.g. sensors), and battery leakage

Coin-Cell Long Range NanoBeacon Use Case #1



Remote Soil Moisture Sensor

Breadboard for Test



Sensor in Ground

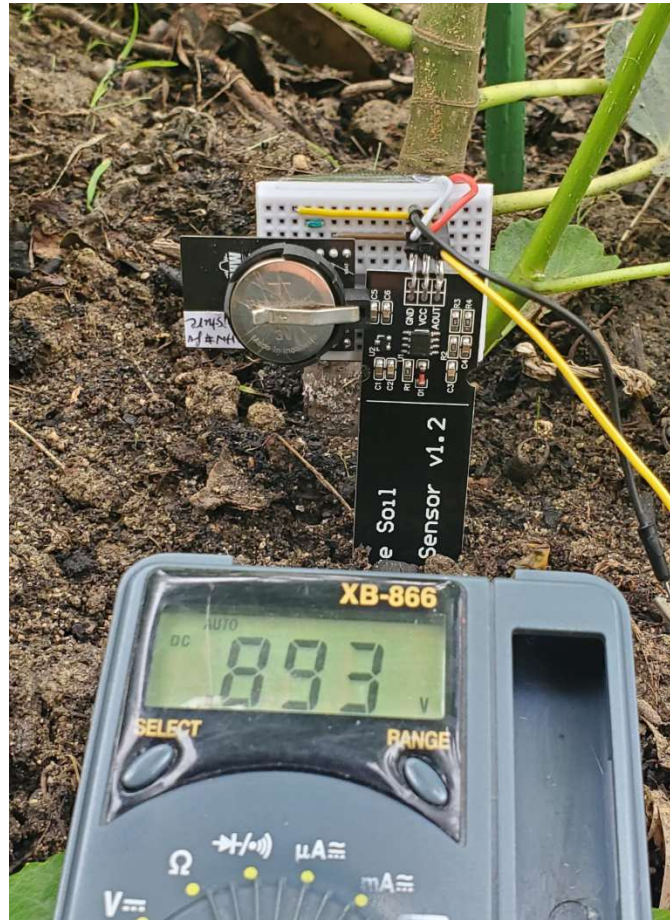

Remote Reading from Phone

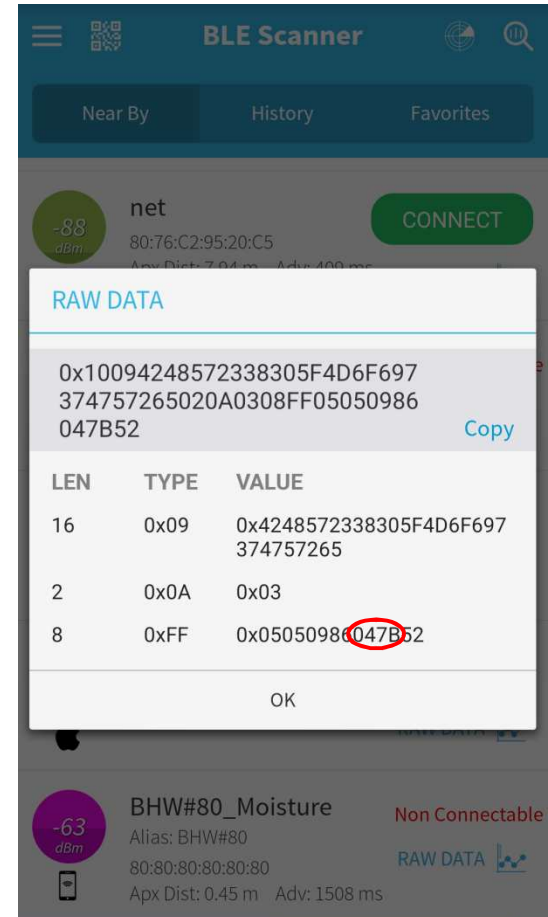

Notes:

- Measured output voltage via ADC1 pin (MGPIO5) is in very good agreement with DMM test result.
- A jumper connection of SW1/SW0 was used temporarily to enable the PA.
- A separate Ni-MH battery was used for power supply to the soil moisture sensor.
- A 360K/360K voltage divider was added to AOUT port to keep ADC input below 1.6V. Actual sensor output is double the reading.
- Need to enable ADC in NanoBeacon Config Tool and Burn/Program with OTP for this test. Contact support@bhwttechnologies.com for details.

ADC1(MGPIO5) Reading:
0x047B (Hex, Big Endian) = 1147 (Decimal)
Convert to Voltage:
1147*0.00078125 = 0.896V

Coin-Cell Long Range NanoBeacon Use Case #2



Remote Temperature Sensor (Up to 300°C)

NanoBeacon with Double Voltage Divider and NTC Thermistor

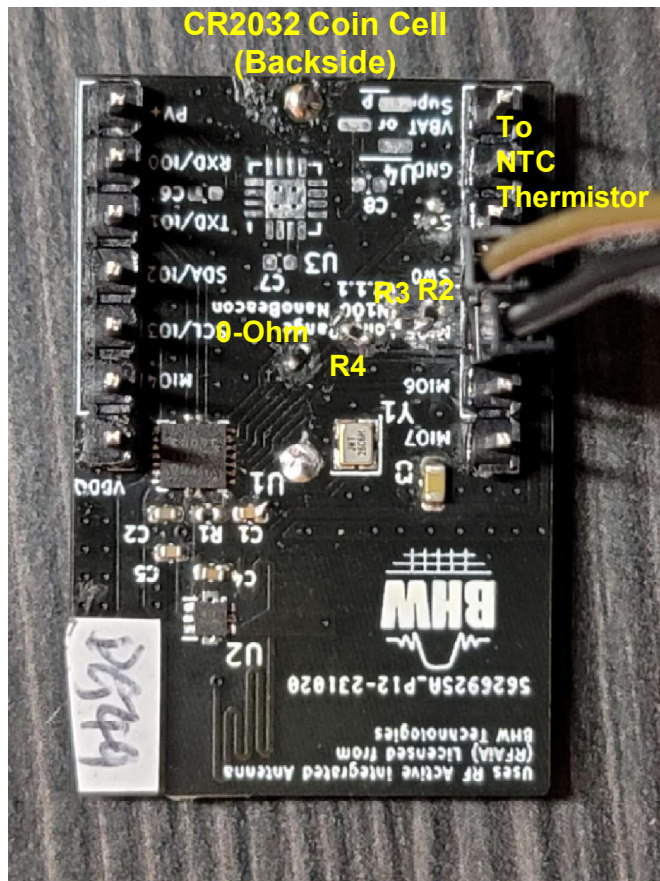

Range Test Result
LOS Range ~ 1.32km

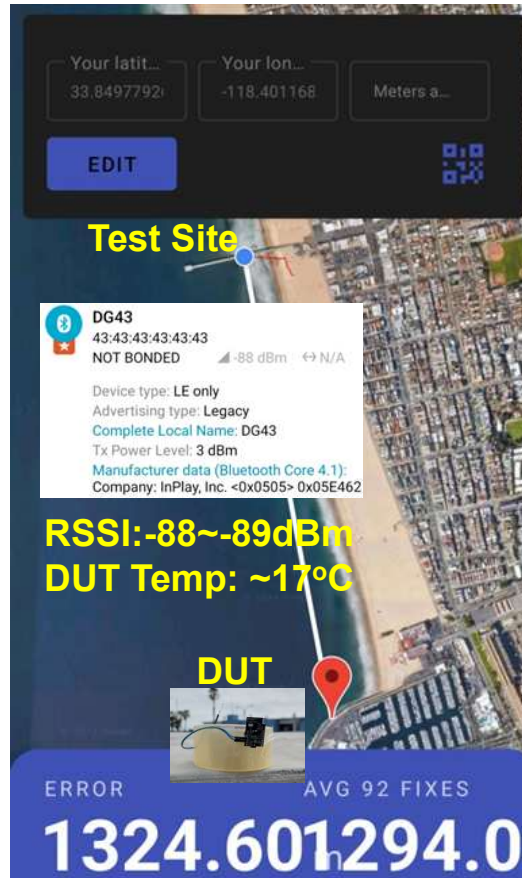

High Temperature Test Result

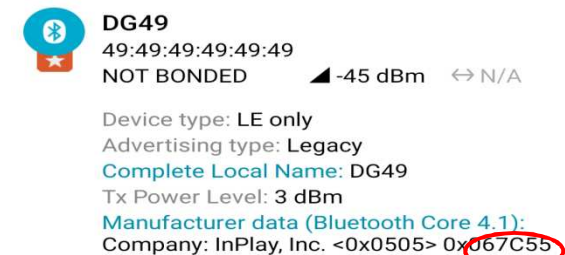

VCC: 55 Hex=85/32=2.65625V
VADC: 067C Hex=1660/1280=1.296875V
Calculated Rt = 12.23 Ohm
Estimated Temp=303.22 °C

Notes:

- IN100 config file has been modified for pulsed bias of both DG103395 and BHW253 PA for low power operation
- Prelim double voltage divider resistor values: R2=680 (to GND), R3=1K, R4=1K(to GND), subject to further optimization for improved accuracy over the desired temp range
- Estimated battery life is ~4 years for CR2032 with 10 second Advertising Interval, and longer for lower duty cycles

Coin-Cell BLE NanoBeacon Range Test Case #1



Open Space, Sandy Beach, Clear LOS (1M PHY)

BHW#84, PCB V1.1.3
IN100 Output = 3dBm
1M PHY, 2 Sec Adv Interval

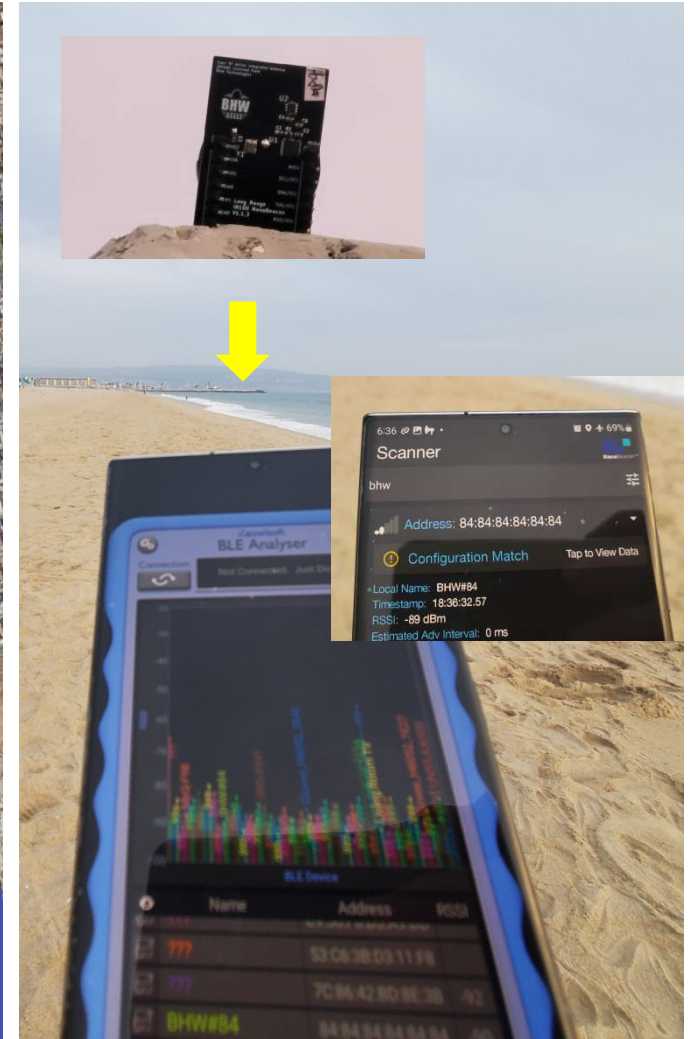
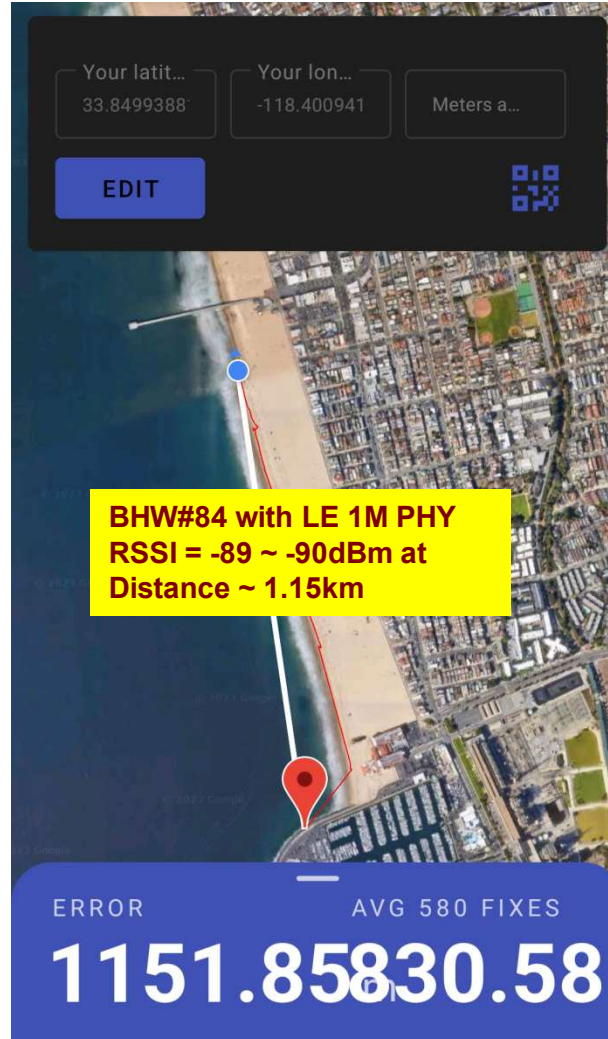

Note: RSSI was measured with NanoBeacon Scanner and BLE Analyzer on Samsung Galaxy Note 20 Ultra. RSSI reading was around -90dBm at 1.15km for 1M PHY. Maximal range is partly limited by Rx sensitivity of the phone and test setup including DUT height. Expect longer range when tested with dedicated BLE gateway.

Coin-Cell BLE NanoBeacon Range Test Case #2



Enhanced LOS Test Using Two City Piers, Coded PHY 125K (S=8)

Expected LOS Range
2.6 km (1.6 mile)

DUT BHW#90
125K/100ms, CR2032 Coin-Cell

Test Result
RSSI ~ -94dBm at 2.6km

Friis Equation

TX $\left(\begin{array}{c} G_t \\ F \end{array} \right) \left(\begin{array}{c} R \\ \end{array} \right) \left(\begin{array}{c} G_r \\ T_a \end{array} \right)$ RX

f 2.45 GHz
 λ 12.2364 cm
BW 2 MHz
Ta 25 °C
Gt 0 dBi
Gr 0 dBi
L 0 dB
NF 3 dB
R 2600 m
Pt 13 dBm
Pr -95.5306 dBm

ERROR AVG 15 FIXES
2601.44 m 2600.62

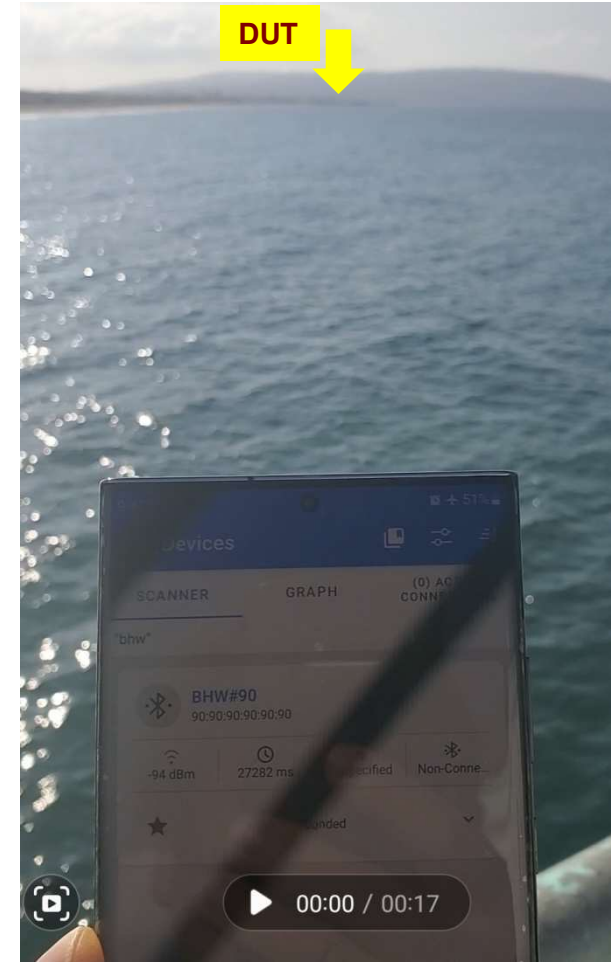
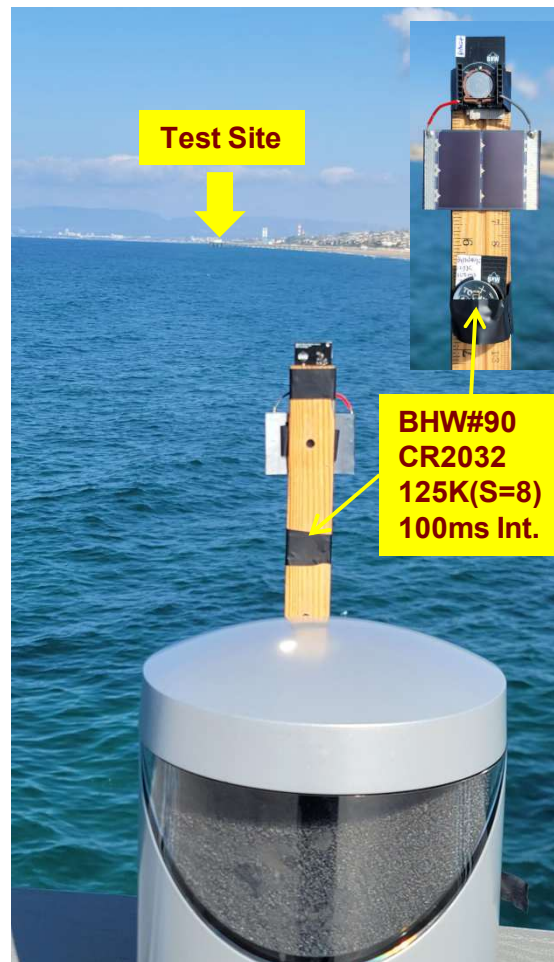

Note: Preliminary test results using Samsung Galaxy Note 20 Ultra BLE scanning APP as RSSI receiver. IN100 output was set at 3dBm to provide transmit power of ~13dBm at antenna feed point. DUTs were taped to a post at a beach pier for maximum ground clearance. RSSI (for 125K) was tested from edge of the second pier for best LOS. Expect better max range when tested with dedicated BLE gateway.

Coin-Cell BLE NanoBeacon Range Test Case #3



Range & RSSI vs Antenna Orientation, Coded PHY 125K (S=8)

DUT Set up
3 Antenna Positions



Distance = 1.67 km
All 3 DUTs Detected

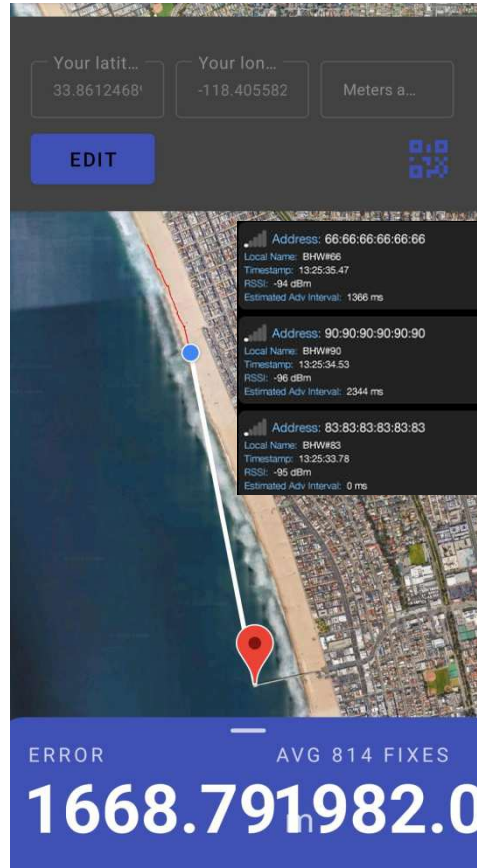

Distance = 2.02 km
2 DUTs Detected

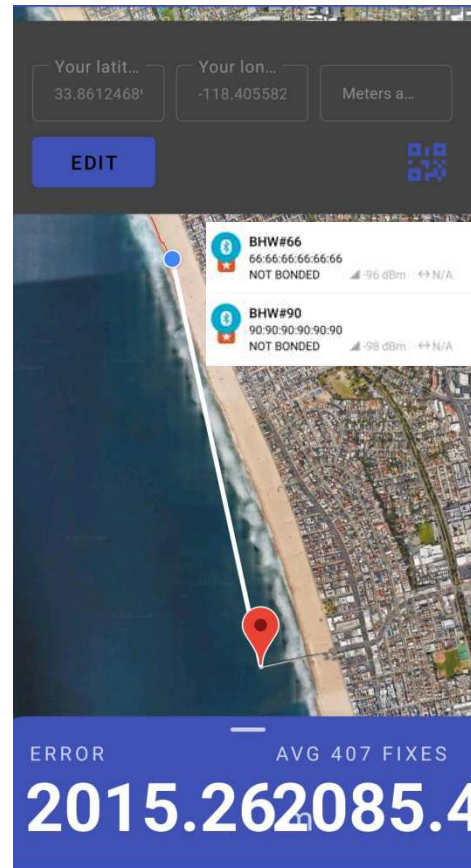

Distance = 2.10 km
1 DUT Detected

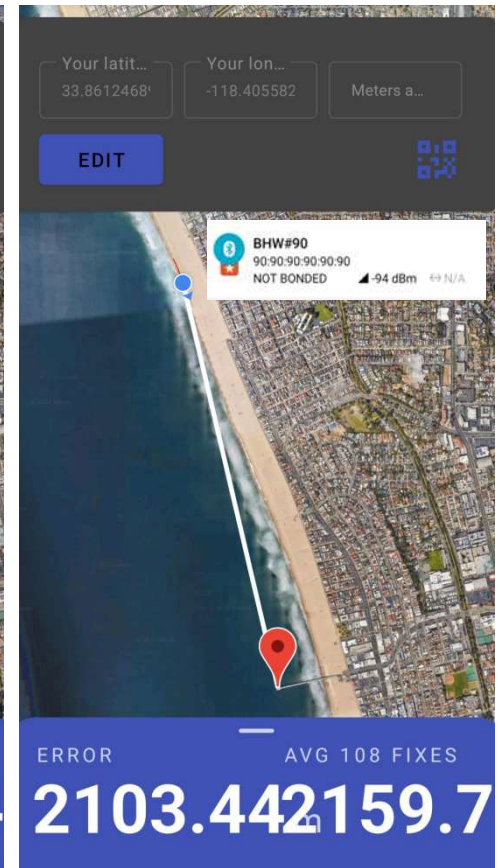

Note: Three DUTs BHW#66/#83/#90 were configured identically with Coded PHY 125K, 100ms Adv Interval. IN100 output was set at 3dBm to provide transmit power of ~13dBm at antenna feed point. DUTs were taped to a wood ruler with three antenna orientations as shown. DUTs were placed at edge of a beach pier for maximum ground clearance for LOS test. Samsung Galaxy Note 20 Ultra was used as RSSI receiver. Expect better max range when tested with dedicated BLE gateway.

Coin-Cell BLE NanoBeacon Range Test Case #4



Park with Grass, Minor Terrain and Light Blocking

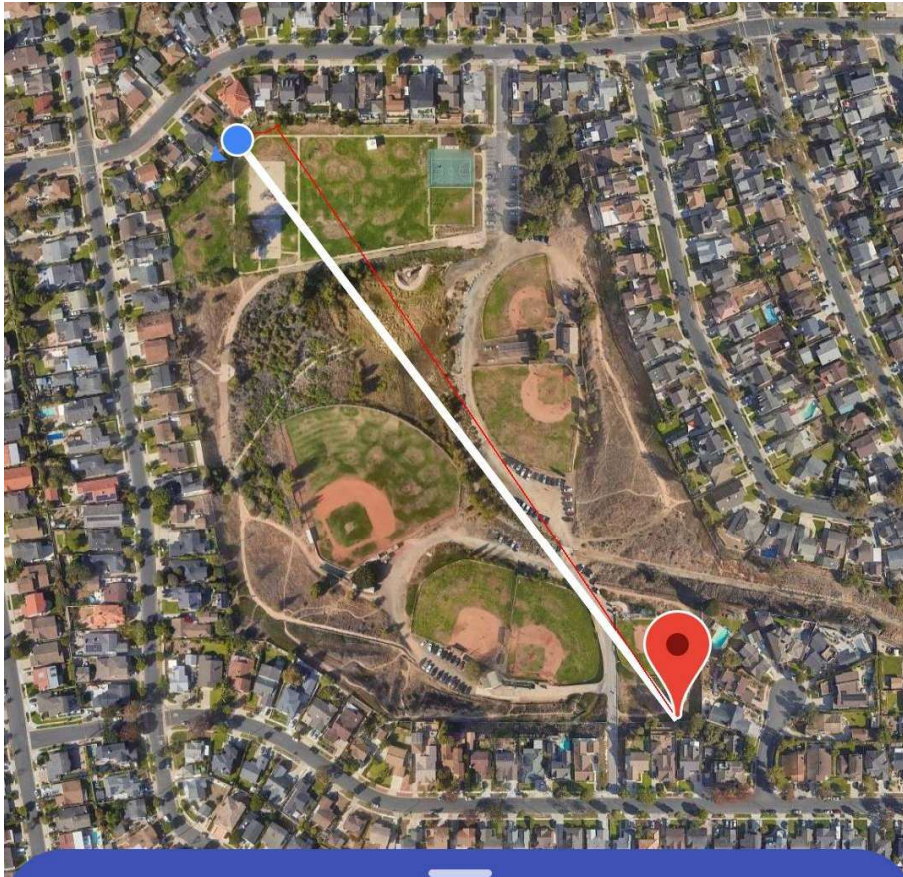

ERROR

AVG 71 FIXES

457.08 m 441.84

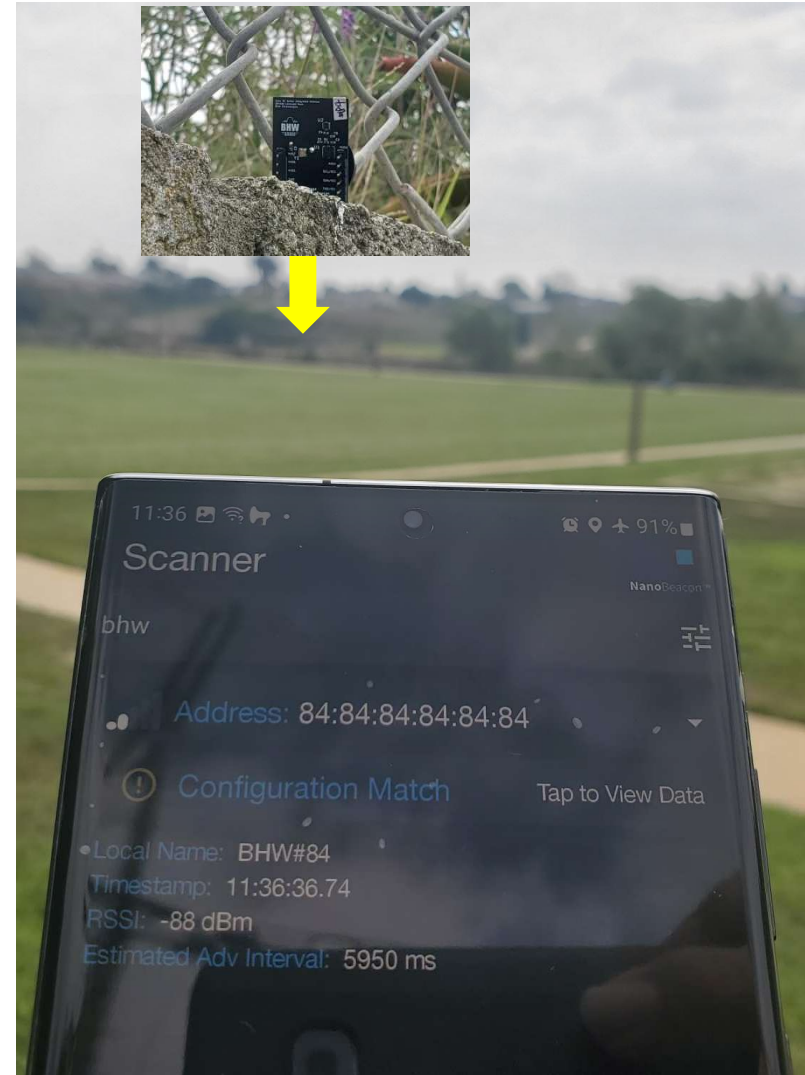

Note: DUT is BHW#84, PCB V1.1.3. RSSI was measured with NanoBeacon Scanner on Samsung Galaxy Note 20 Ultra. RSSI reading was -88dBm at ~457m(edge of the park), with LE 1M PHY. Expect >1km range when using dedicated BLE gateway and improved test setup.

Coin-Cell BLE NanoBeacon Range Test Case #5



Parking Lot Drive Way, Concrete Surface, LOS

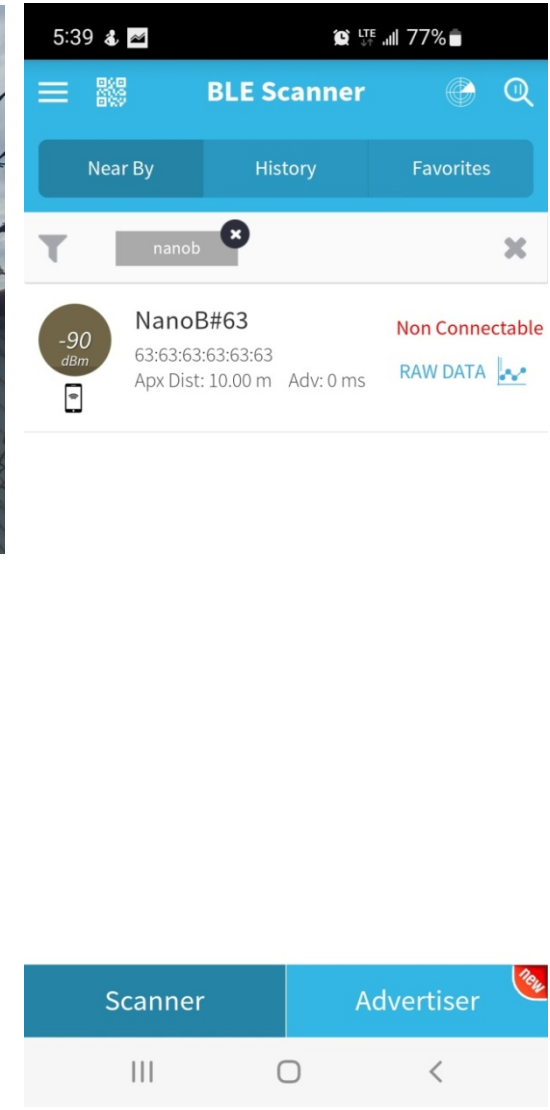
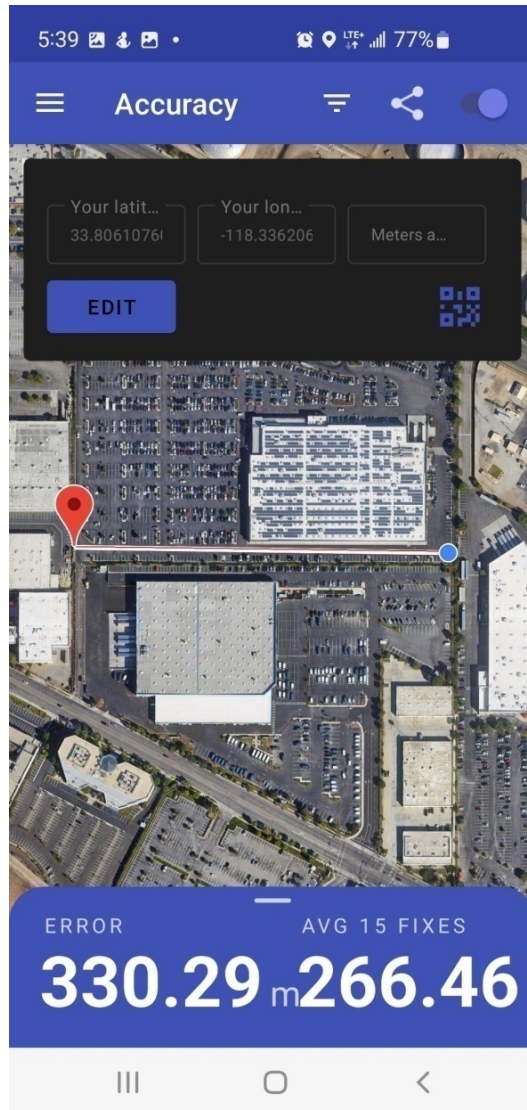

Note: DUT is NanoB#63, PCB V1.1.2. RSSI is -90dBm at ~300m, with LE 1M PHY. Test limited by property boundary for LOS.

Coin-Cell BLE NanoBeacon Range Test Case #6



City Street, Near-LOS

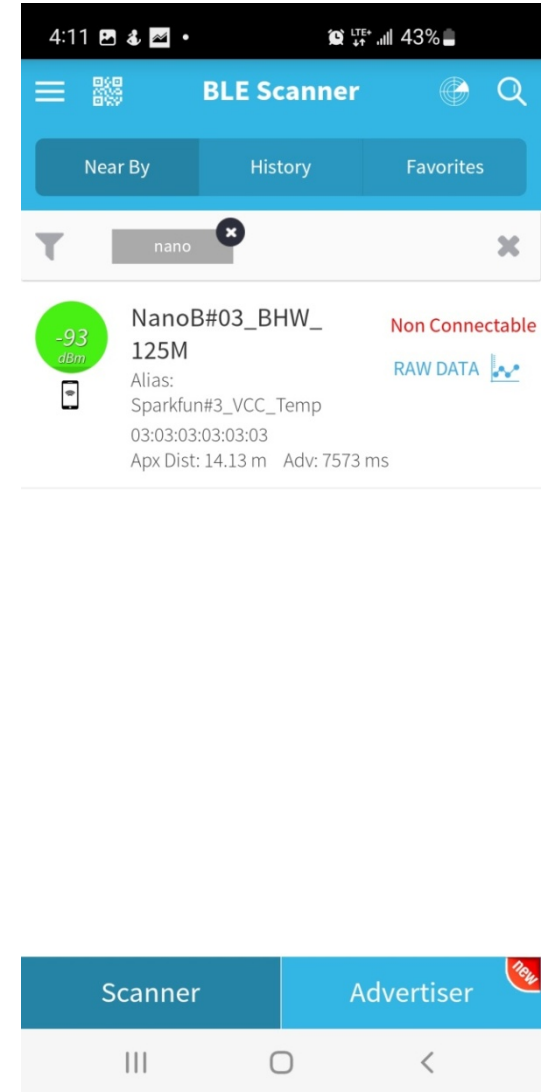
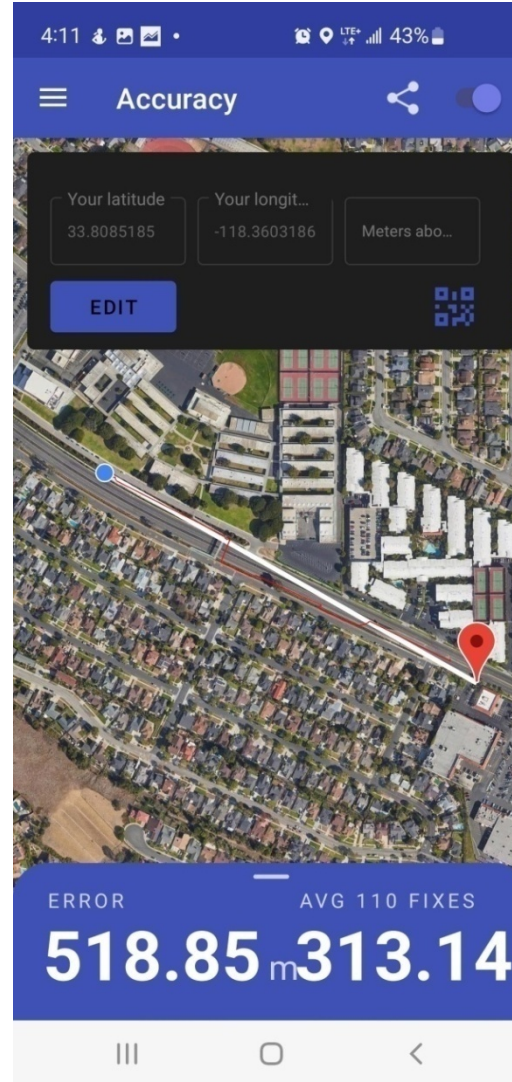

Note: RSSI is -93dBm at ~520m, with LE Coded PHY 125K, limited likely by Rx sensitivity of the phone and tree blocking effects.

Coin-Cell BLE NanoBeacon Range Test Case #7



Commercial Building, Non-LOS (Bing Crosby Hall, Del Mar Fairgrounds)

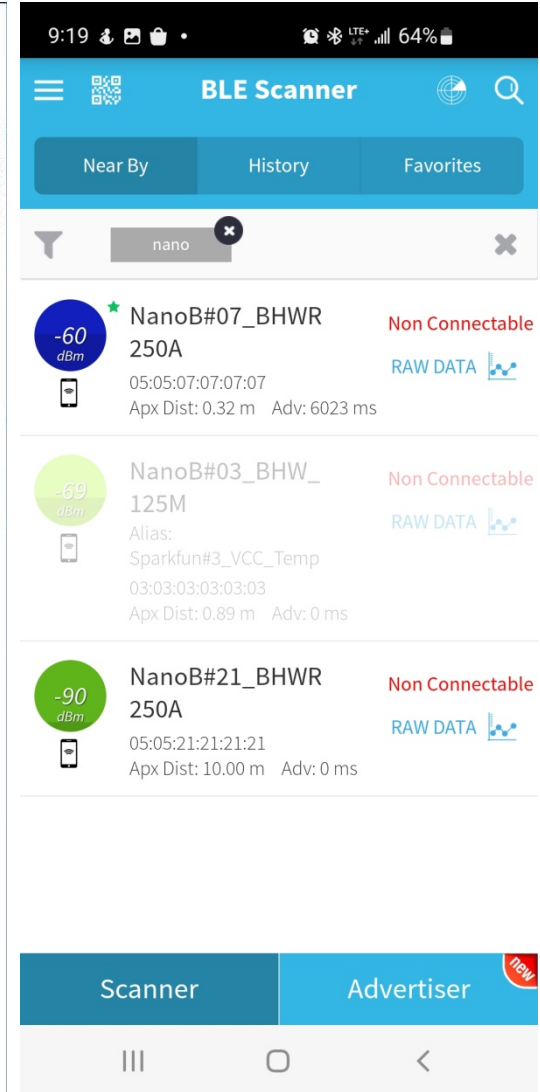
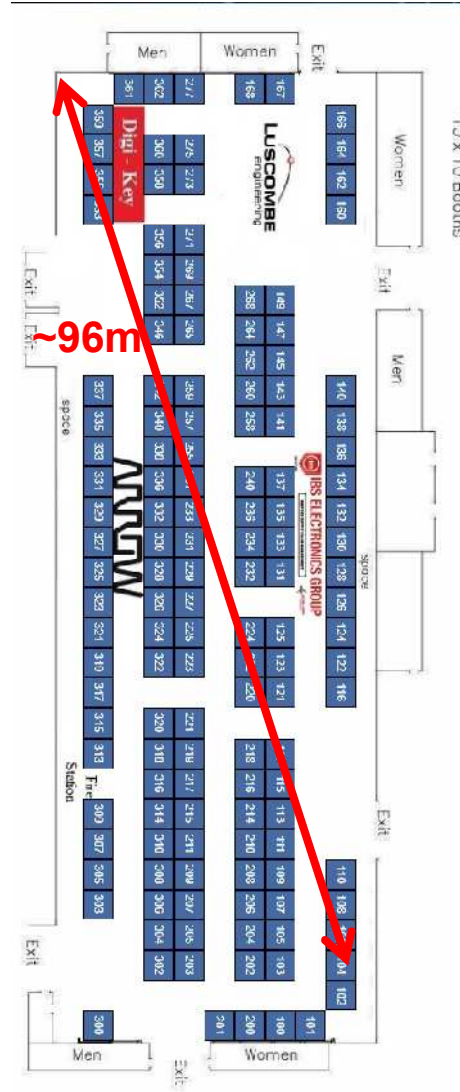
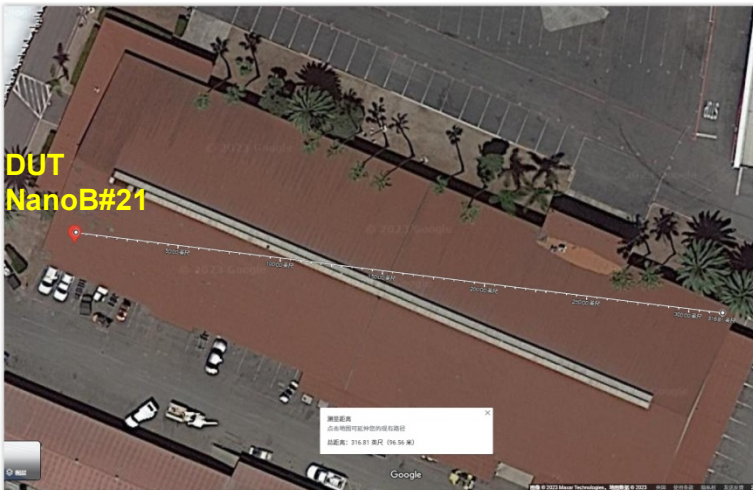

Note: RSSI is -90dBm at ~96m across the exhibition hall, Non-LOS, with LE Coded PHY 125K, during off-show time. RSSI test was unsuccessful during DMEMS show hours due to too congested Bluetooth user traffic.

Coin-Cell BLE NanoBeacon Range Test Case #8



Multi-Storey Parking Lot, Non-LOS



Non-LOS test with minor blockage by concrete walls and other parked vehicles



Test sample BHW#62 placed on top to SUV parked at Level 2 of a 3-Level parking building

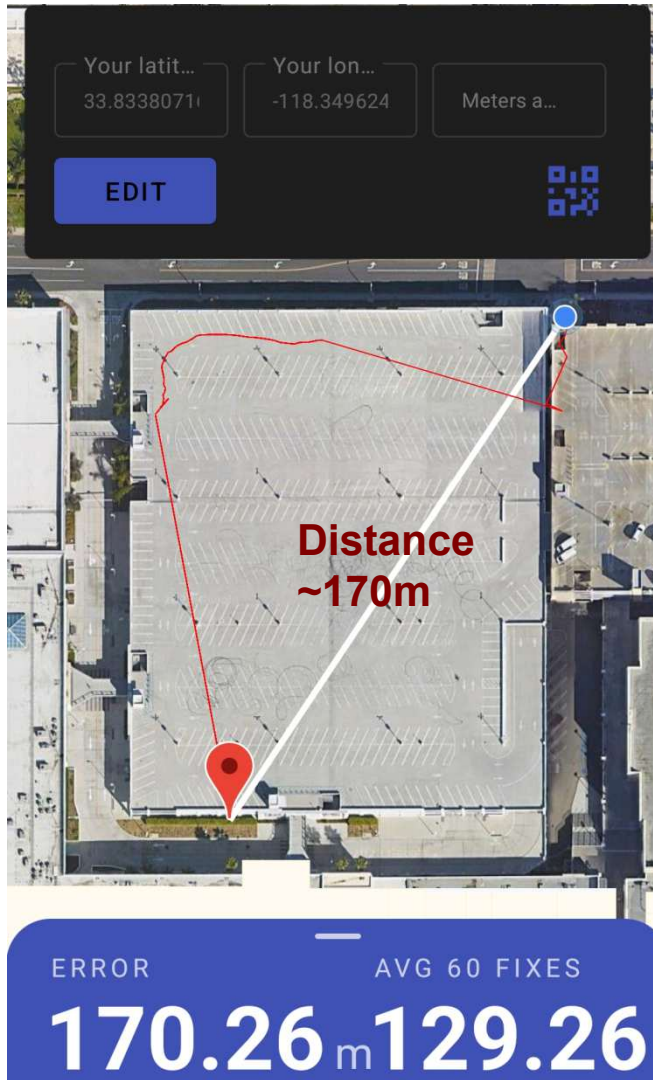

Coin-Cell BLE NanoBeacon Range Test Case #9



Range Test with Ultra-Small Coin Cell CR1225

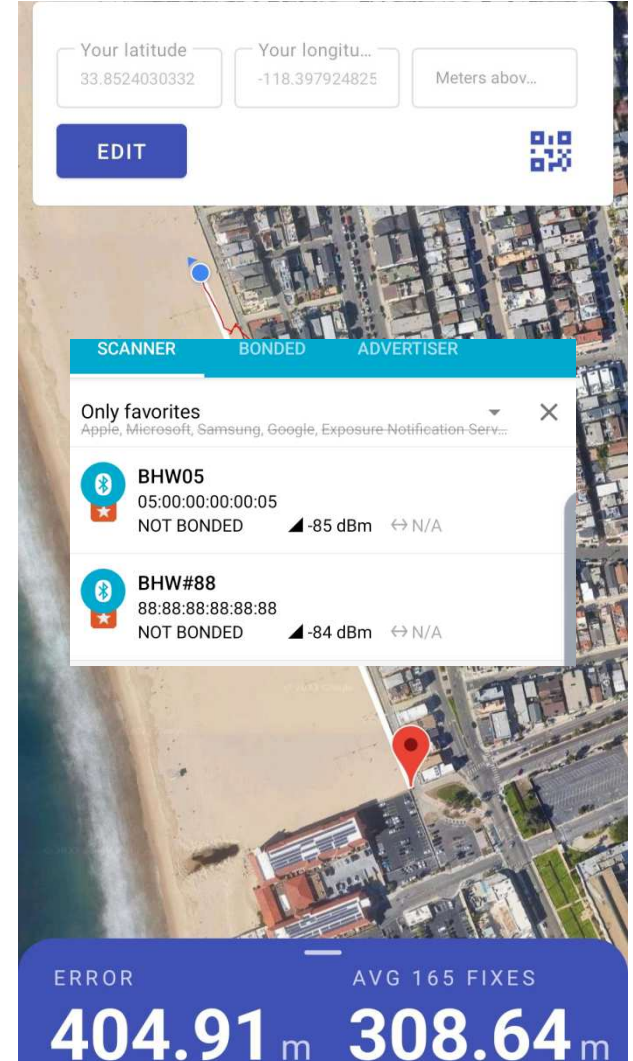
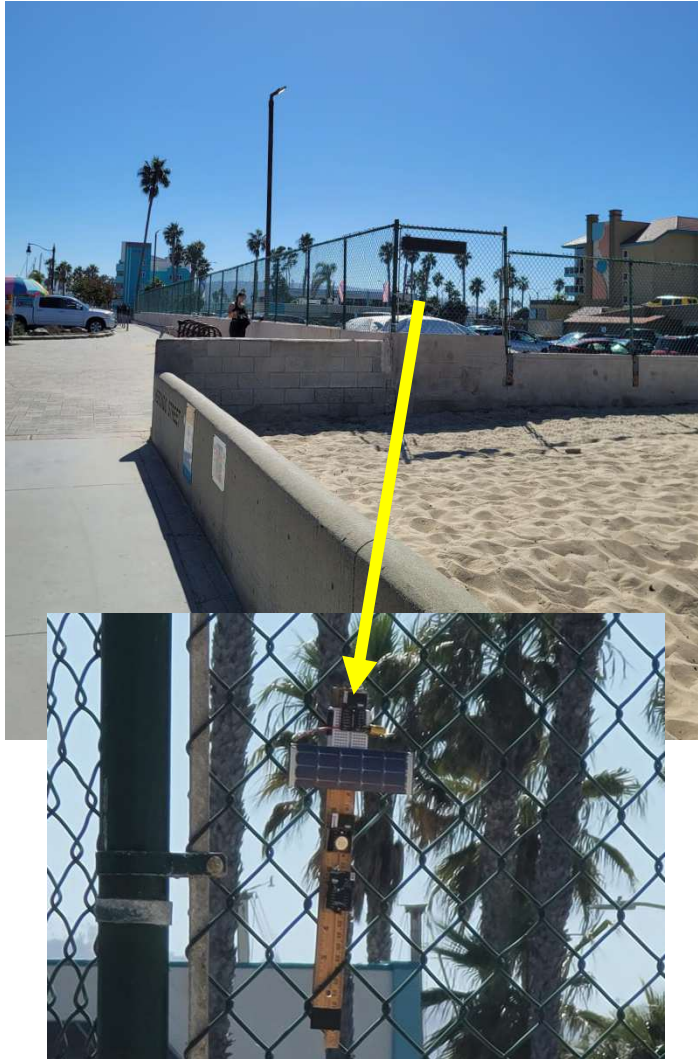

Note: DUT BHW05 with CR1225. DUT BHW#88 with CR2032. Both DUTs configured for LE 1M PHY, 2sec Advertising Interval. DUTs taped to a wood ruler and placed ~2m above ground. RSSI measured with Samsung Galaxy Note 20 Ultra. Measured RSSI were ~-85dBm at ~400m, similar between two DUTs using CR1225 and CR2032 coin cells, respectively.



Use Case #2

Batteryless Long Range NanoBeacon Using Energy Harvesting

Batteryless Long Range NanoBeacon EVB



Front-Side, Rev. 2.1.1

U1: InPlay IN100 SoC 3x3mm QFN
 U2: BHWM253, U3: NEH2000BY, U4: LDO

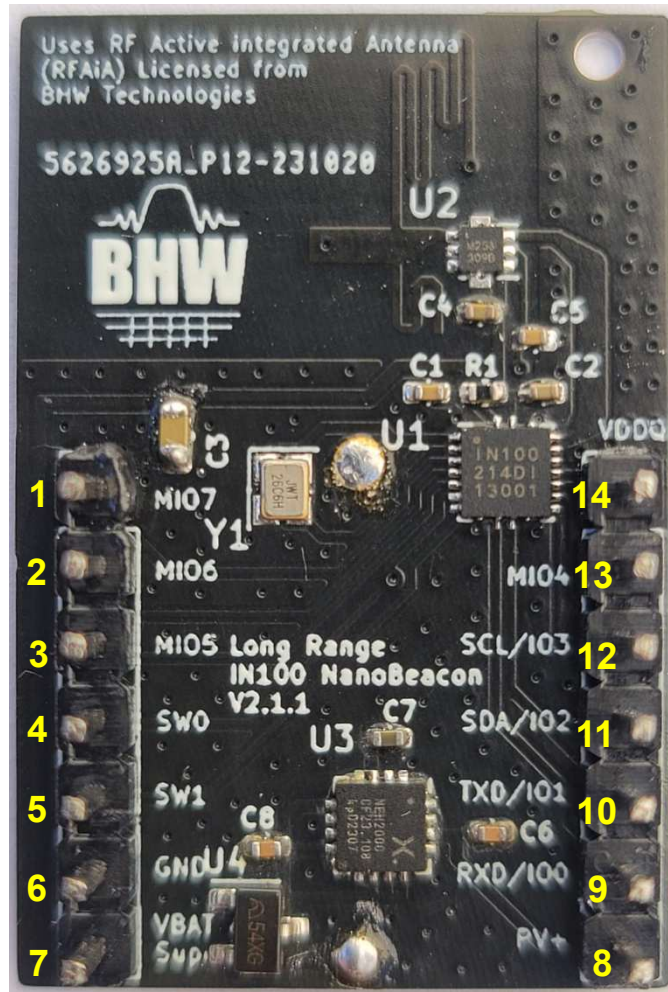

Back-Side, Rev. 2.1.1

Center: CR1632/2032/LIR1220 Battery Holder
 Top-Right: Slot Antenna of BHWR250A



Notes:

-Battery holder pitch is 16.66mm for CR1632, or CR2032 with minor pitch adjustment. Alternatively a CR1225/LIR1220 battery holder can be soldered directly to PCB on the back side. Use VBAT (Pin 7) for other options of power supply.

Batteryless Long Range NanoBeacon Schematic



Reference Schematic and Nominal BOM, Rev. 2.1.1

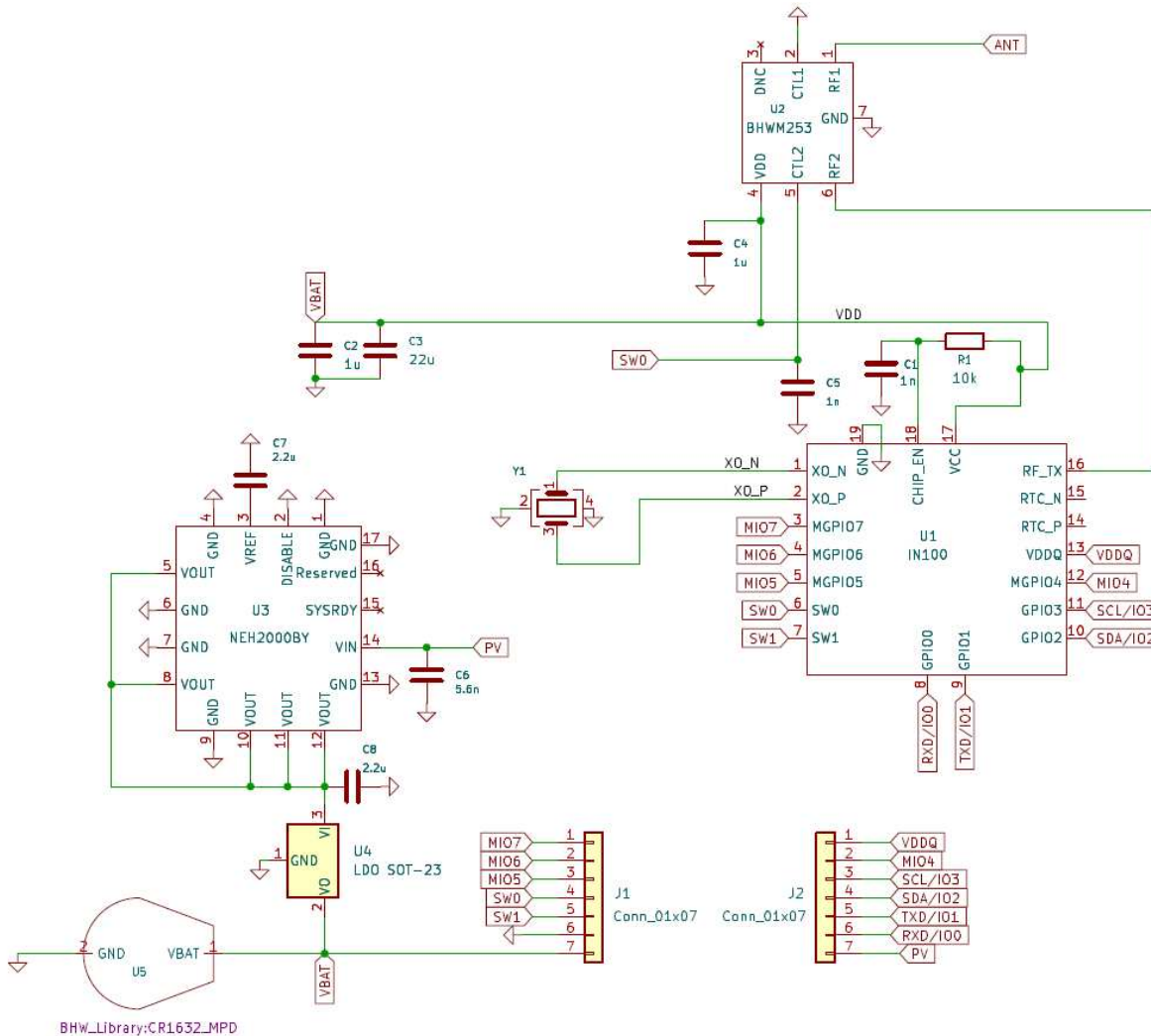

Nominal BOM:

C1=C5=1nF
 C2=C4=1uF
 C3*=22uF
 C6=5.6nH
 C7=C8=2.2uF
 R1=10 Kohm

U1: IN100 3x3mm QFN-18
 U2: BHWM253 1.5x1.5mm DFN-6
 U3: NEH2000BY PMIC 3x3mm QFN-16
 U4**: LDO SOT-23
 U5: Battery CR1225/1632/2032 w/o EH;
 SuperCap or Rechargeable batteries with EH
 Y1: 26MHz Crystal
 (See IN100 Datasheet for AVL of Y1)

Note*: C3 values between 10uF to ~470uF can be used for different types of coin-cell batteries. If available for space and cost, larger-value capacitors are recommended for very small coin cells such as LIR1220. Larger capacitors especially electrolytic caps may have higher leakage current compared to ceramic caps.

Note**: LDO output voltage should be selected to match the voltage ratings of super capacitors or rechargeable batteries. Maximum voltage is 3.6V. Alternatively, an OVP device can be used to avoid battery over-charging. Refer to Nexperia Application Note AP90040 for details.

Coin-Cell/Batteryless Long Range NanoBeacon PCB



Front-Side PCB View, Rev. 2.1.1

U1: InPlay IN100 SoC 3x3mm QFN

U2: BHWM253, U3: NEH2000BY, U4: LDO

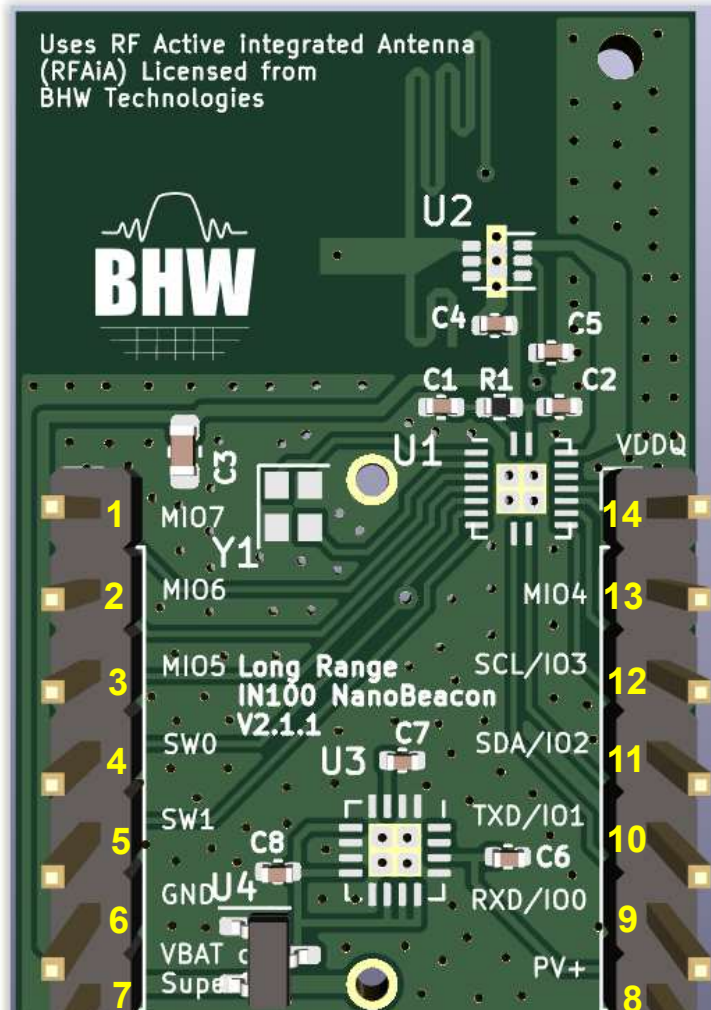

Back-Side PCB View, Rev. 2.1.1

Center: CR1225/1632/2032 Battery Holder

Top-Right: Slot Antenna of BHWR250A

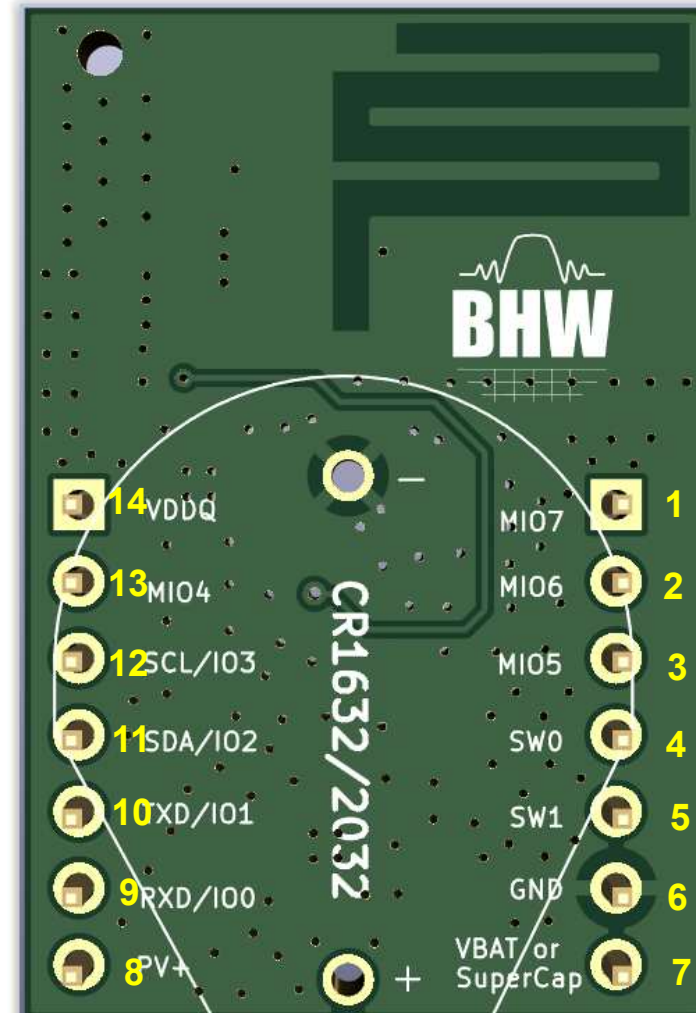

-Battery holder pitch is 16.66mm for CR1632, or CR2032 with minor pitch adjustment. Alternatively a CR1225/LIR1220 battery holder can be soldered directly to PCB on the back side. Use VBAT (Pin 7) for other options of power supply.

-Gerber file of the 2-Layer, 0.8mm thick FR4 PCB design of this Long Range NanoBeacon can be downloaded at www.bhw-tech.com/appnotes

Batteryless Long Range NanoBeacon EVB



Measured VSWR of Slot Antenna of BHWR250A AiA, EVB Rev. 2.1.1

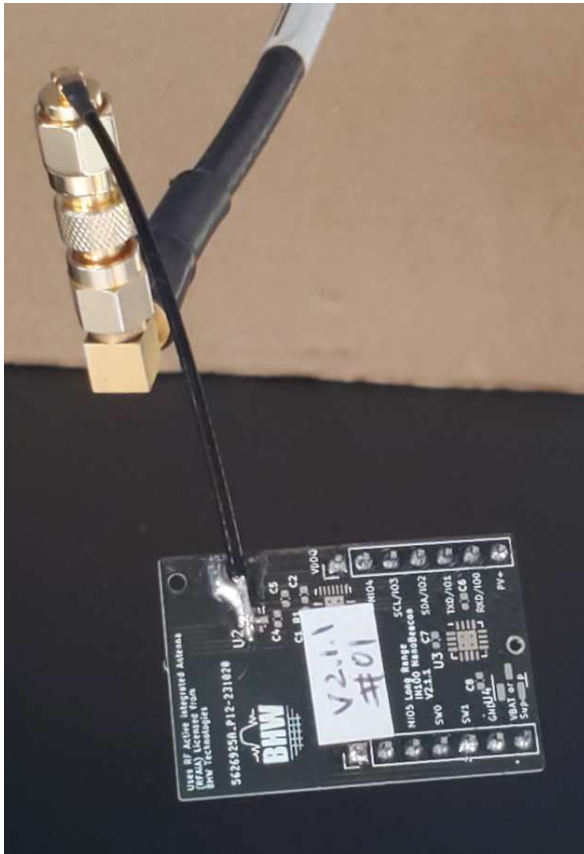

Keysight Technologies: N9923A, SN: 0

Thu, 10 Feb 2022 9:56:59 AM

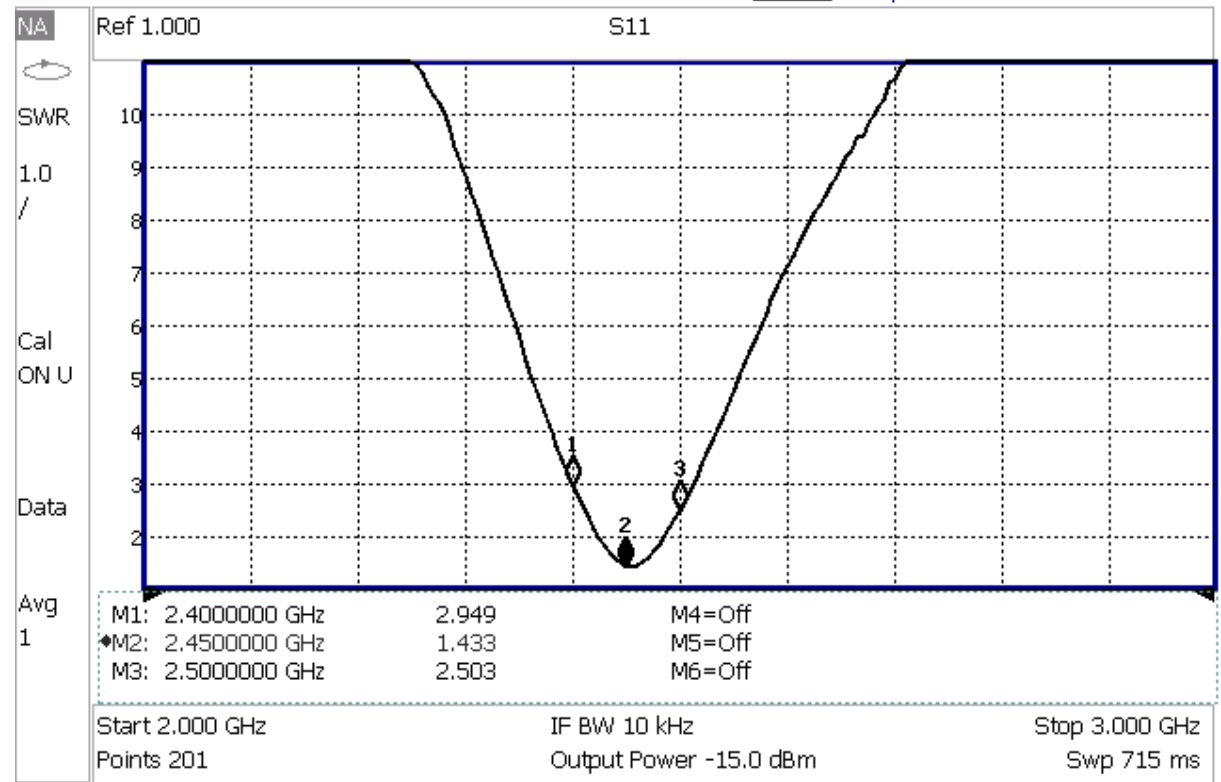

Notes:

- 1) Antenna VSWR is stable when measured with or without pin headers, as well as when mounted on a breadboard.
- 2) Refer to Appendix 1 for further details of BHWR250A AiA.

Batteryless Long Range NanoBeacon EVB



VSWR Stability of Slot Antenna of BHWR250A AiA, EVB Rev. 2.1.1 Antenna at Center of Breadboard

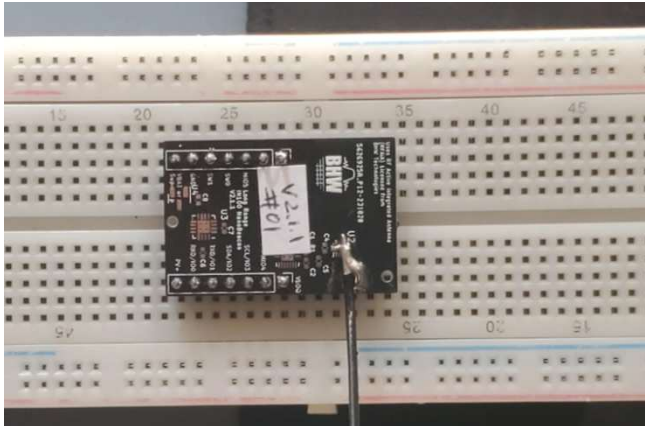

Keysight Technologies: N9923A, SN: 0

Thu, 10 Feb 2022 10:02:53 AM

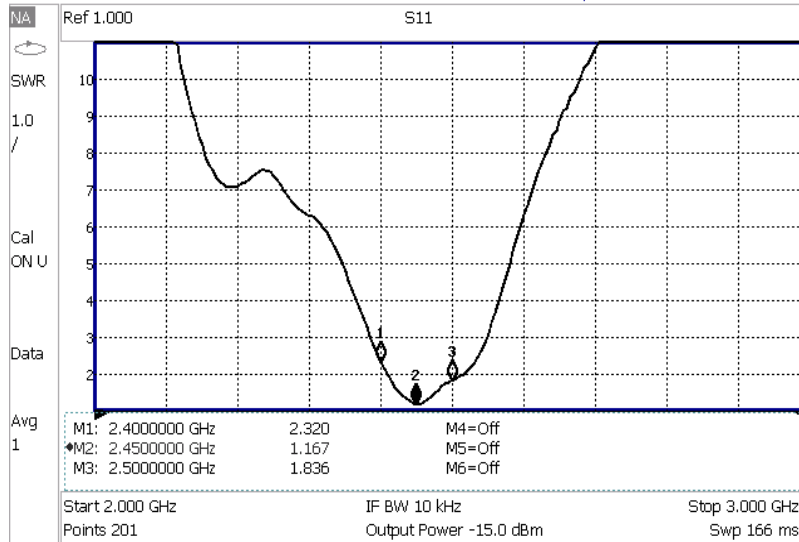

Antenna at Edge of Breadboard

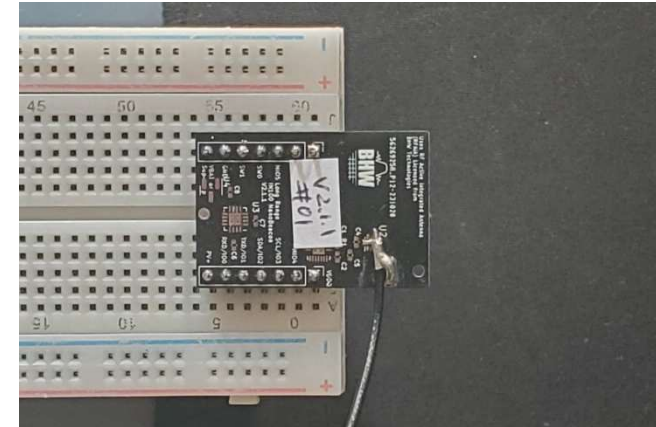

Keysight Technologies: N9923A, SN: 0

Thu, 10 Feb 2022 10:01:21 AM

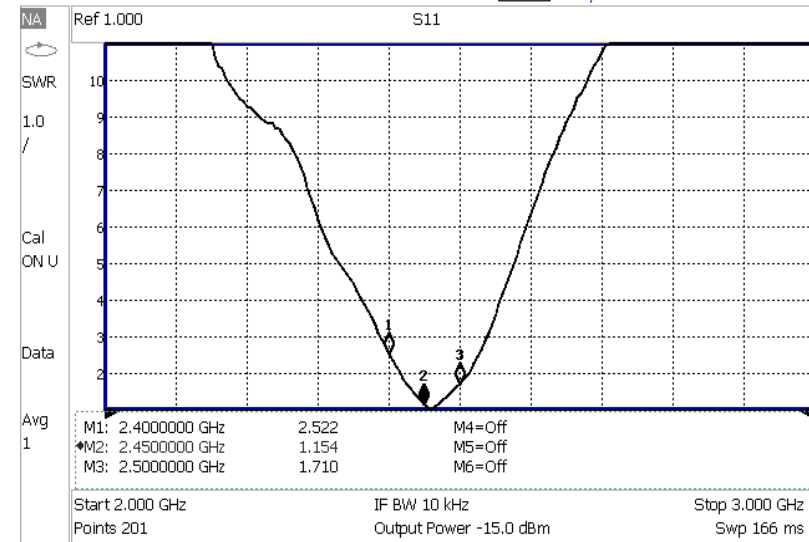

Note: Antenna VSWR varies only slightly when the NanoBeacon board with pin headers is mounted on a typical breadboard, at the center or towards the edge.

Batteryless Long Range NanoBeacon Implementations



Examples of Various Combinations for Energy Harvesting, PMIC & Storage

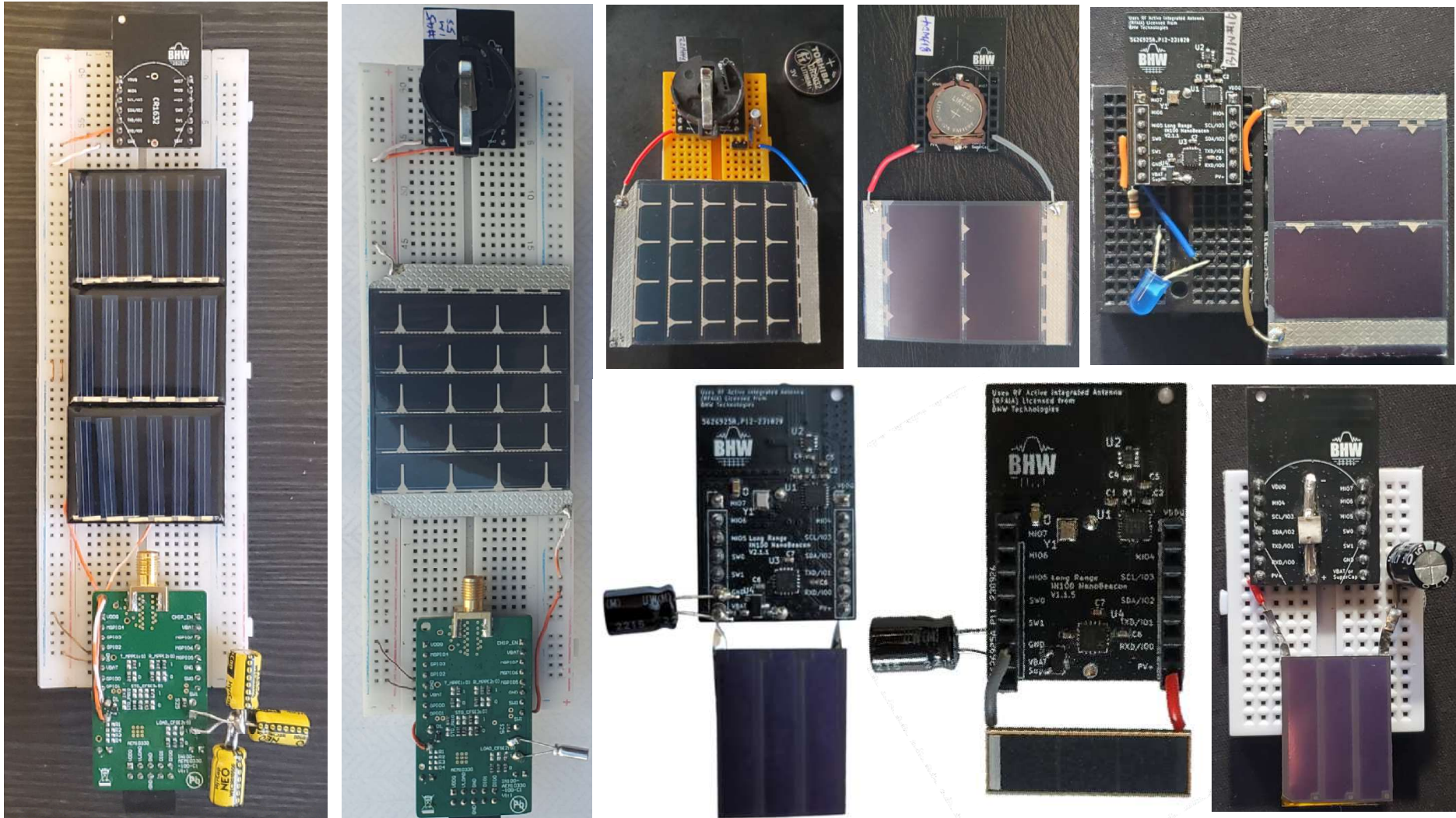

Notes: While NEH200BY is for PV only, energy sources other than solar can be used for harvesting, such as RF, thermal, kinetic, acoustic, or aquatic. Energy harvesting and storage components should be selected and sized properly for anticipated energy consumption for different use cases (duty cycles, Coded PHY, etc). Choose PMIC and associated OVP devices properly in accordance with each specific EH strategy.

Batteryless Long Range NanoBeacon Case Study #1



Proof-of-Concept Breadboard for EH with Compact PV Cell, NEH2000BY and SuperCap

Front Side

Back Side

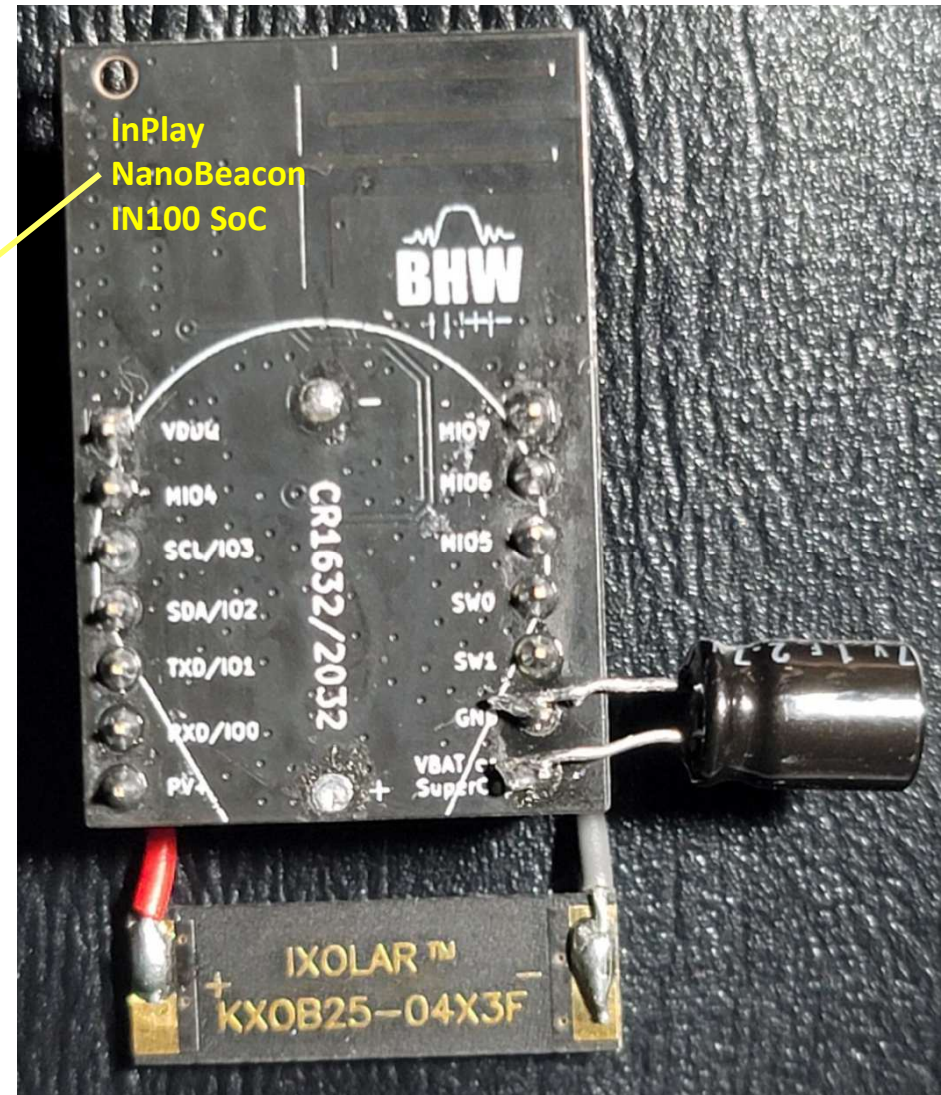
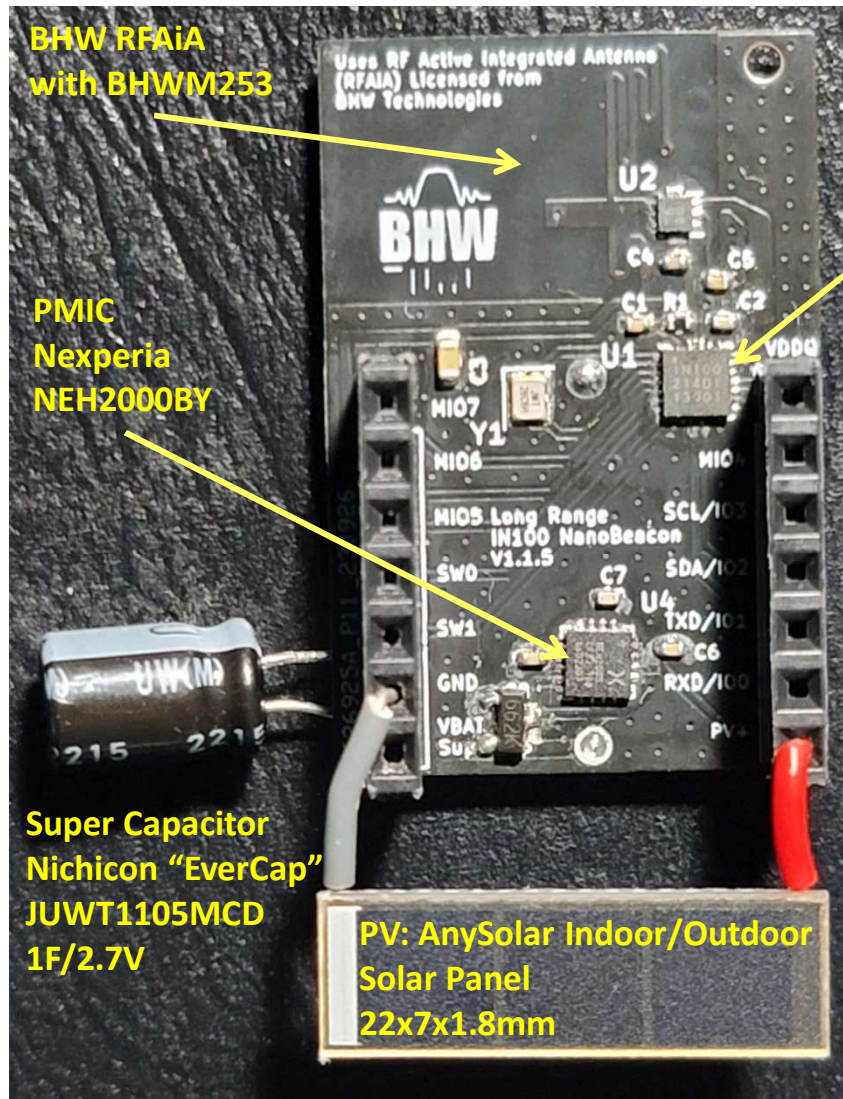

Batteryless Long Range NanoBeacon Case Study #1



Range Test of Breadboard for EH with Compact PV Cell and SuperCap, LE 1M PHY

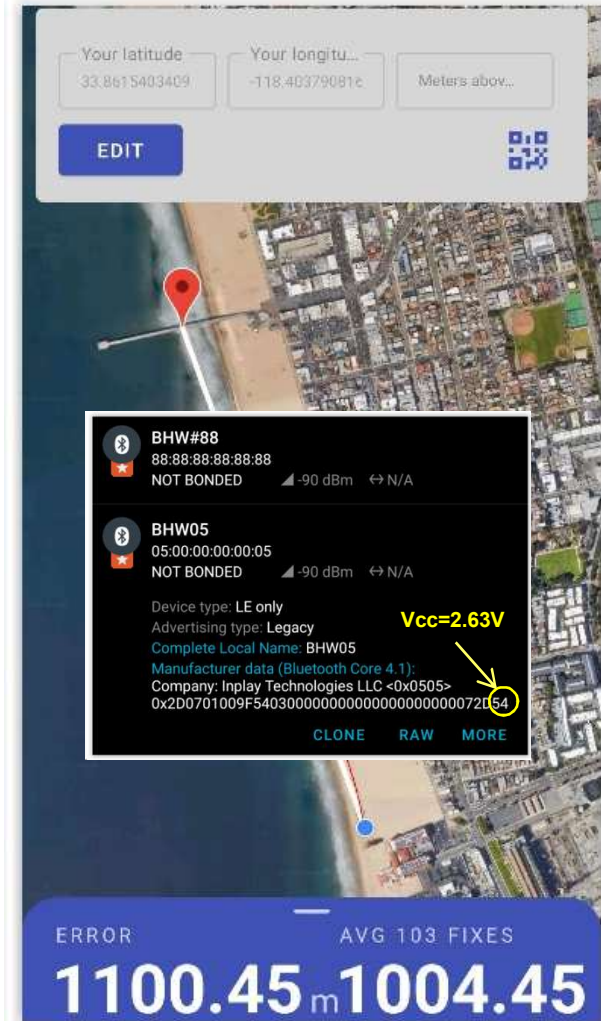
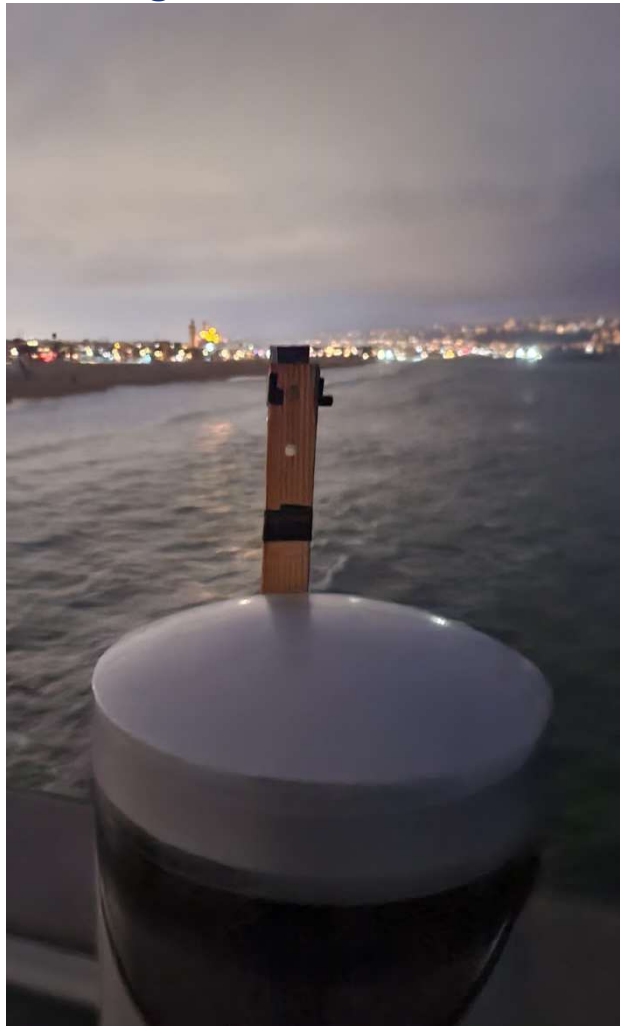

Note: Preliminary test results only. Measured RSSI is -90dBm at ~1.1km for LE 1M PHY, Advertising Interval 2000ms. RSSI were similar for DUT BHW05 with PV+SuperCap and DUT BHW#88 with LIR1220 rechargeable battery. Range test is limited likely by receive sensitivity of the phone (Samsung Galaxy Note 20 Ultra). Expect improved results for maximal range when tested with dedicated gateway with better antenna and Rx sensitivity.

Batteryless Long Range NanoBeacon Case Study #2



Proof-of-Concept Test of EH with Small PV Film and SuperCap, LE 1M PHY

DUT #15
Eddystone TLM

DUT Setup
For LOS Range Test

RSSI ~ -91dBm
At 1.1km, 1M PHY

Super Capacitor
Nichicon
"EverCap"
JUWT1105MCD
1F/2.7V

PV Film
TDK
BCSC45B3
25x19mm
19uA*1.5V@200Lx

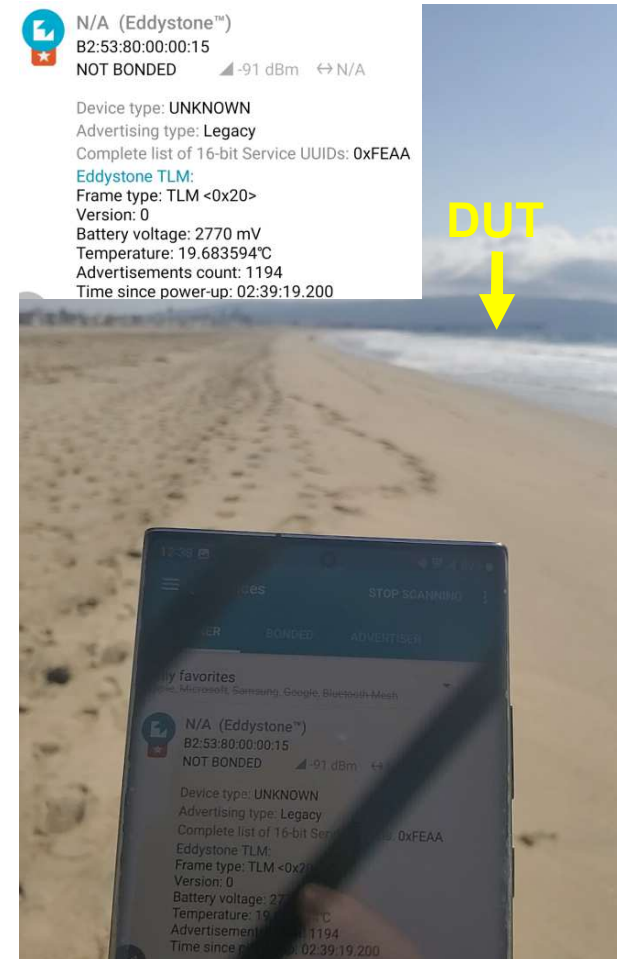
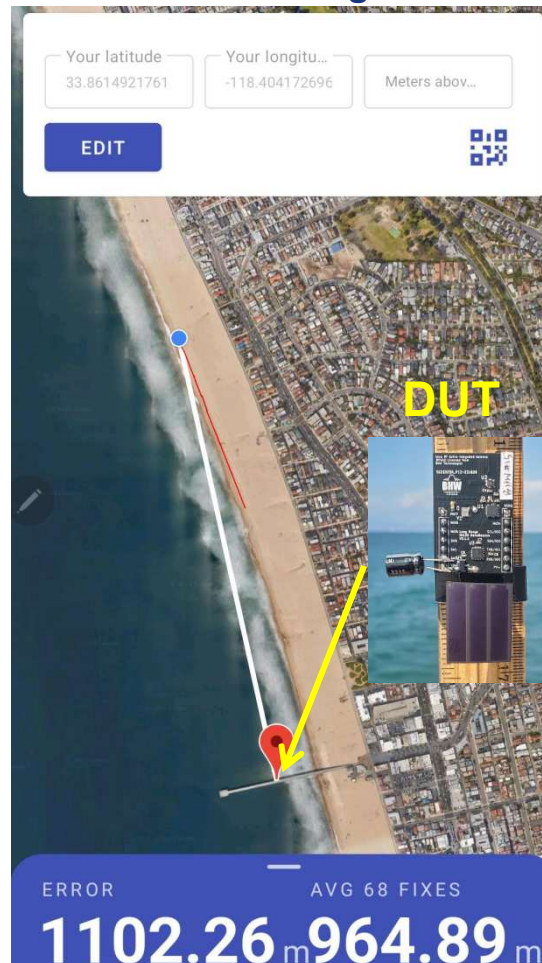

Note: Preliminary test results only. Measured RSSI is -91dBm at ~1.1km for LE 1M PHY, Advertising Interval 8000ms. Range test is limited likely by receive sensitivity of the phone (Samsung Galaxy Note 20 Ultra). Expect improved results for maximal range when tested with dedicated gateway with better antenna and Rx sensitivity.

Batteryless Long Range NanoBeacon Case Study #3



Proof-of-Concept for Energy Harvesting with PV Film, NEH2000BY PMIC & LTO Battery

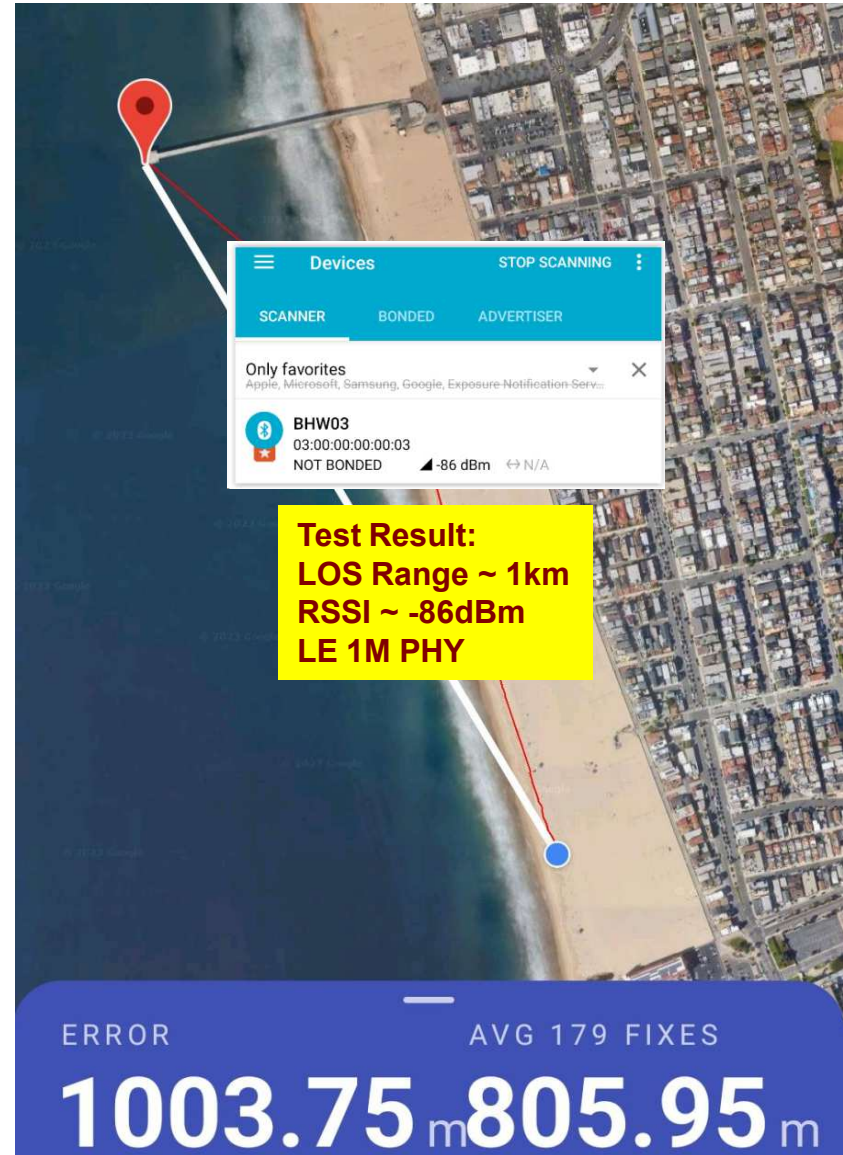
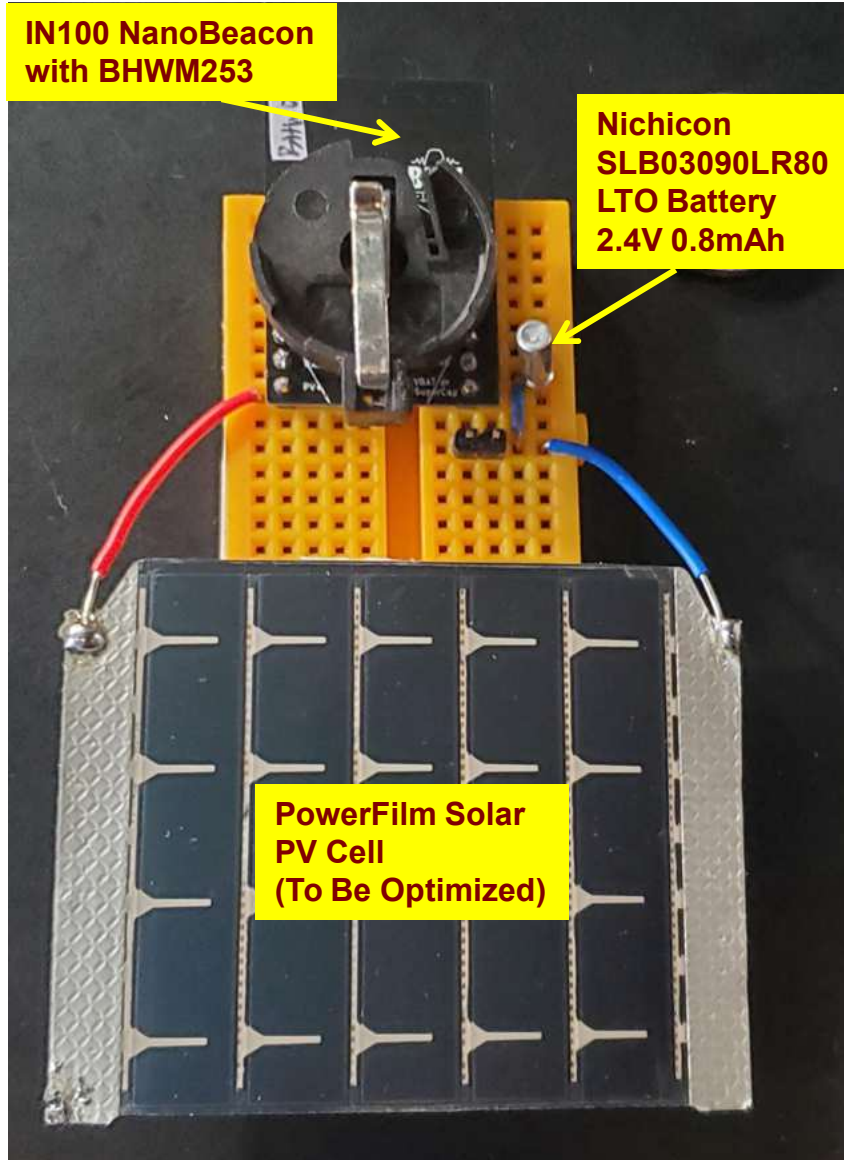

Batteryless Long Range NanoBeacon Case Study #4



Proof-of-Concept Breadboard for EH with PV Film, NEH2000BY and Rechargeable Coin-Cell

Front Side

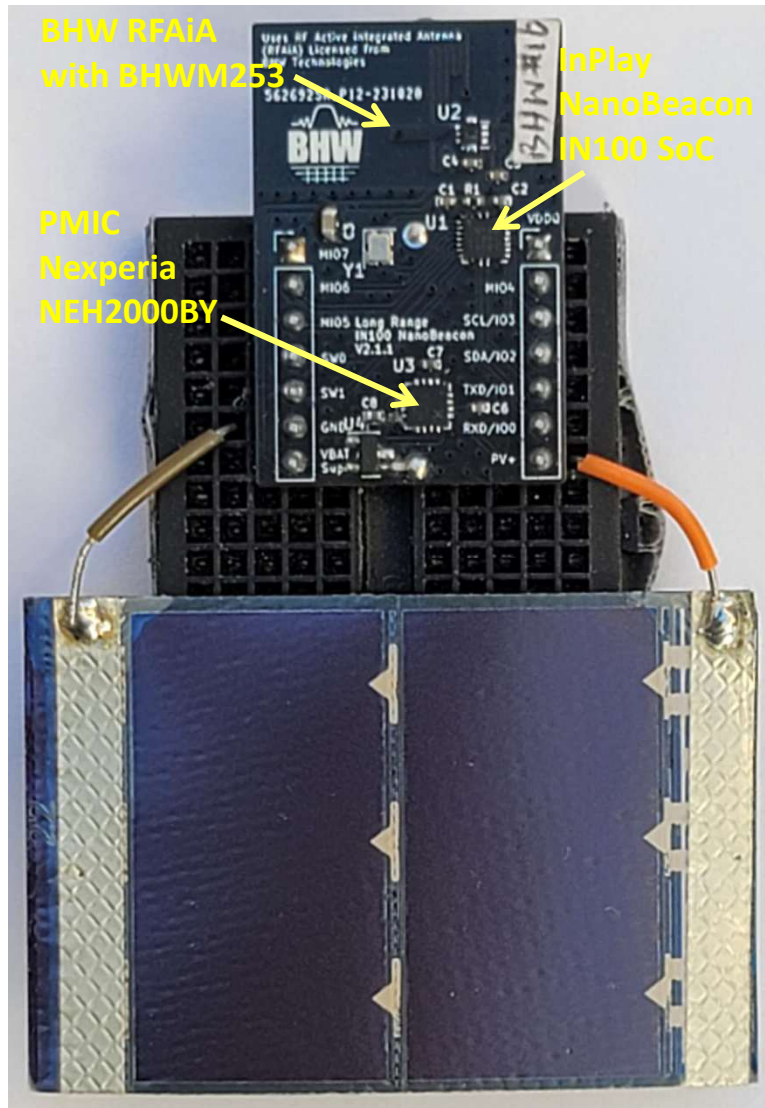

Back Side



Batteryless Long Range NanoBeacon Case Study #4



Range Test of Breadboard for EH with PV Film and LIR1220, LE Coded PHY 125K

Expected LOS Range
2.6 km (1.6 mile)

DUT BHW#16
125K/3sec, LIR1220 Coin-Cell

Test Result
RSSI ~ -95dBm at 2.61km

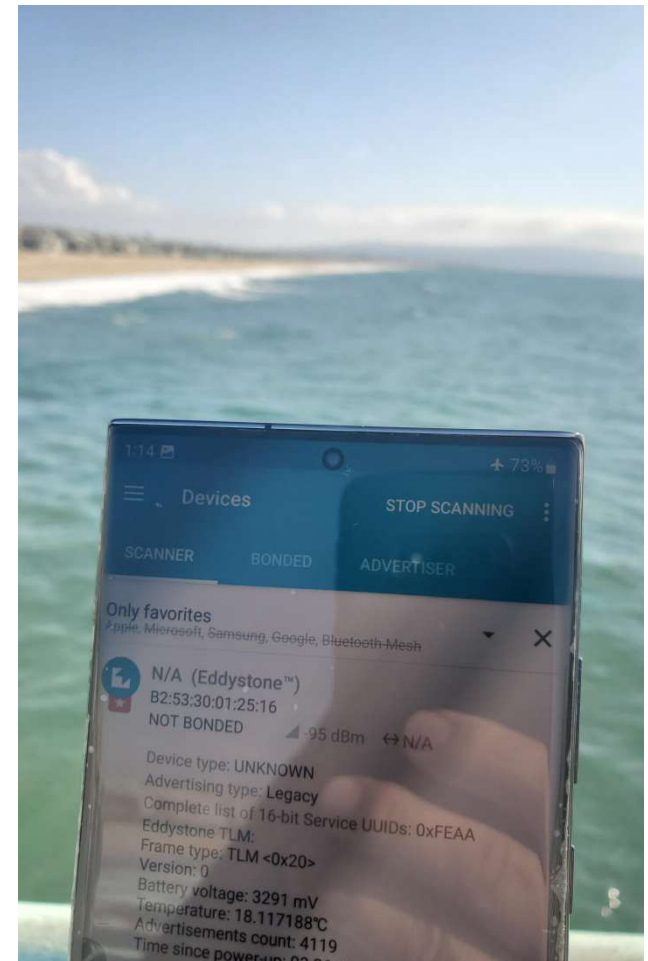
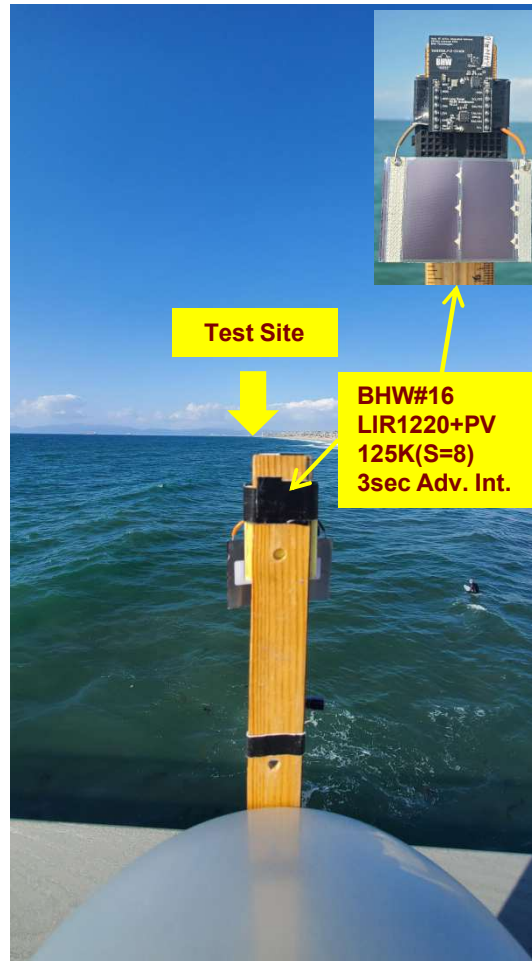

Note: Preliminary test results only. Measured RSSI is -95dBm at ~2.61km for LE Coded PHY 125K (S=8), Advertising Interval 3000ms. Range test is limited likely by receive sensitivity of the phone (Samsung Galaxy Note 20 Ultra). Expect improved results for maximal range when tested with dedicated gateway with better antenna and Rx sensitivity.

Long Range NanoBeacon with 1M vs Coded PHY



Comparison of Advertisement Duration for LE 1M PHY vs Coded 125K PHY

DUT NanoB#66, 1M PHY
Advertising Time ~0.38ms for Each Adv. Channel

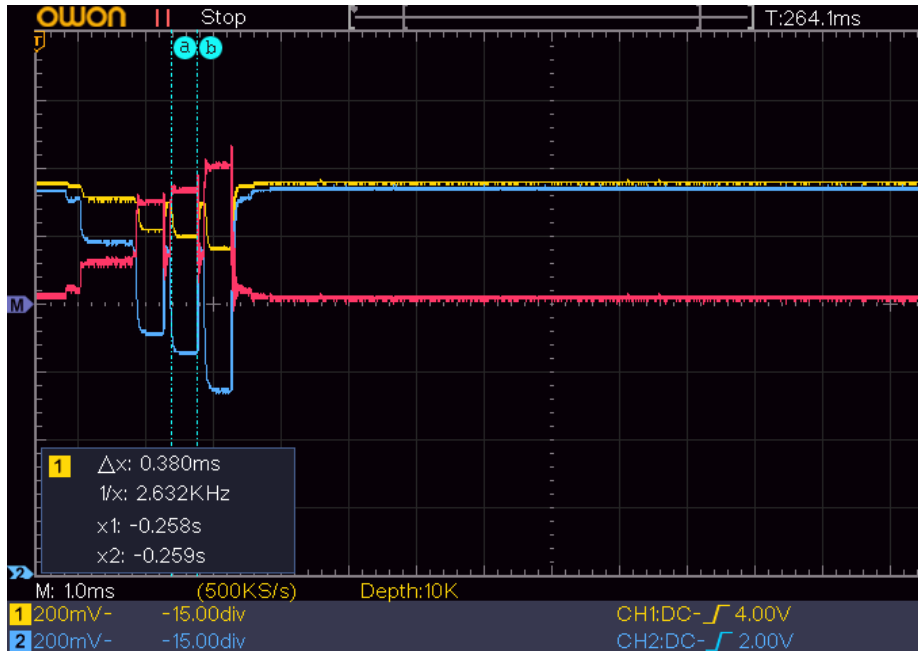

DUT NanoB#25, 125K PHY
Advertising Time ~3.1ms for Each Adv. Channel

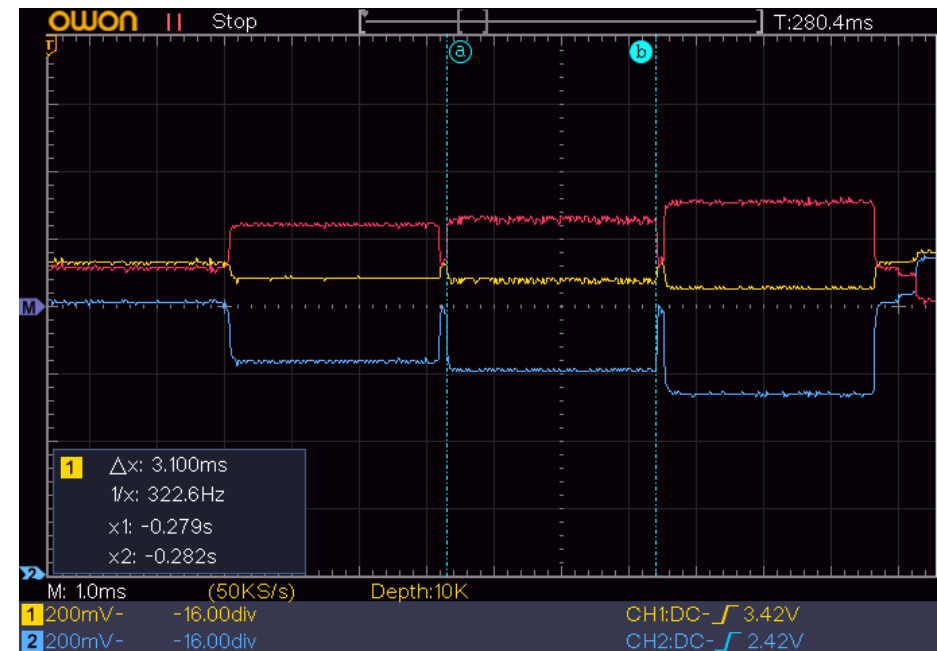

Notes:

- 1) Beacon Payload was 31 bytes for both DUTs.
- 2) Advertising time was ~0.38ms for each of the 3 adv. channels for 1M PHY, and ~3.1ms for 125K Coded PHY (S=8).
- 3) Although Coded PHY can provide longer range due to the use of FEC, it requires much longer (~8x) packet transmit time, thus consuming much higher power than that of 1M PHY.
- 4) The combination of IN100 SoC and BHWR250A AiA helps achieve both high data rate (1M PHY) and long range (>1km) simultaneously, at much lower total power consumption than typical BLE Class-1 solutions using 20dBm PAs.
- 5) For applications with less power budget limitations, we can use 125K PHY to further increase maximum range to well beyond 1mile, as indicated by measured data on pages 15, 16 and 35.

Long Range NanoBeacon with 1M vs Coded PHY



Comparison of Energy Consumption Per Beacon for 1M vs Coded 125K PHY

DUT BHW#15, 1M PHY
13.0nAh or 46.9uC per Beacon Event

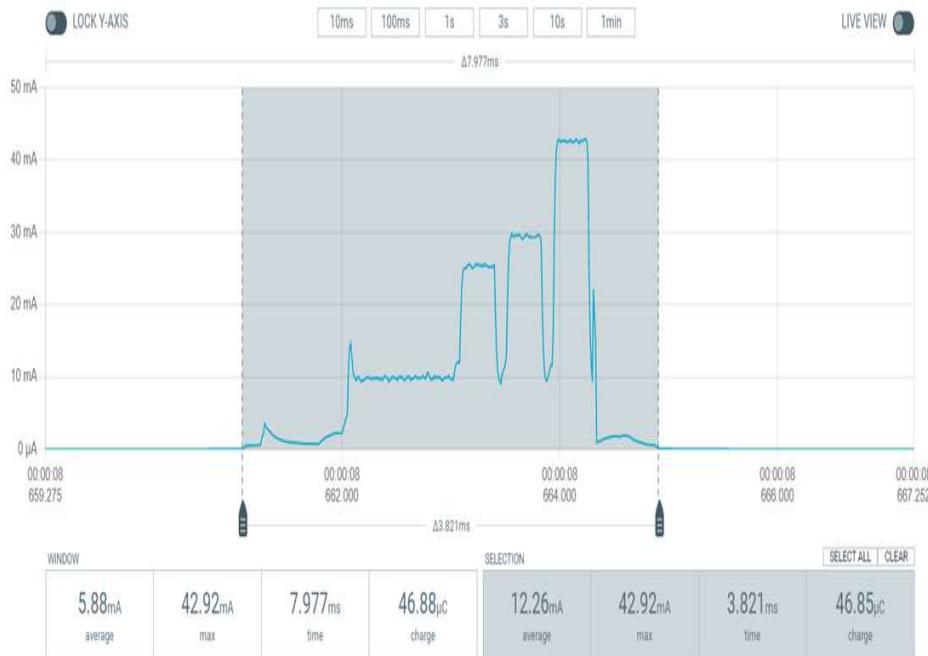

DUT BHW#16, Coded PHY 125K (S=8)
69.3nAh or 249.5uC per Beacon Event



Notes:

- 1) Power Profile Kit II (PPK2) from Nordic Semiconductor was used for current/power measurement.
- 2) Payload was 22 bytes for both DUTs that were configured as Eddystone TLM beacons.
- 3) Supply voltage was set at 3.0V for both DUTs, using the Source Meter Mode of PPK2.
- 4) Due to longer time needed to transmit the 125K Coded PHY packets, energy consumption per beacon event (three channels at ~13dBm Tx power) was about 5.3x that for the same payload using 1M PHY.
- 5) For applications with less stringent power budget limitations, such as energy harvesting based NanoBeacons that will have constant in-coming energy to compensate for battery/supercap depletion over time, we can consider using 125K PHY to significantly increase maximum range of operation (4x according the Bluetooth SIG).



References

-InPlay IN100 NanoBeacon SoC and Dev Kit

www.inplay-tech.com/in100

IN100 Datasheet and NanoBeacon User Guide available for download

-BHW BHWR250A AiA

www.bhw-tech.com/rfaias

BHWR250A datasheets available for download

-Nichicon Super Capacitors and Rechargeable Batteries for Energy Storage

www.nichicon.co.jp

-Nexperia NEH2000BY PMIC for Energy Harvesting

<https://nexperia.com>

-e-peas AEM Series PMIC for Energy Harvesting

<https://e-peas.com>

-TDK Indoor PV Films and CeraCharge Solid-State Rechargeable Batteries

<https://tdk-electronics.tdk.com>

-AMETHERM NTC Thermistors

<https://www.ametherm.com/thermistor/>



Appendix 1

BHWR250A 2.4GHz 4-in-1 Active Integrated Antenna for Single-Port SoC

BHWR250A 2.4GHz AiA for Tx Improvement

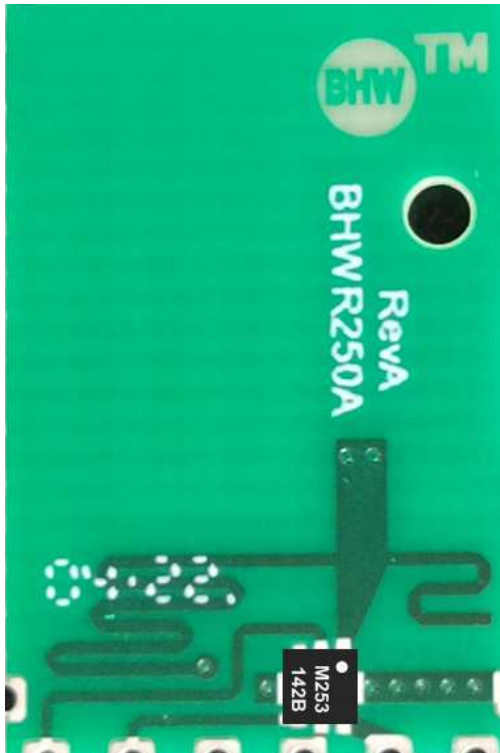
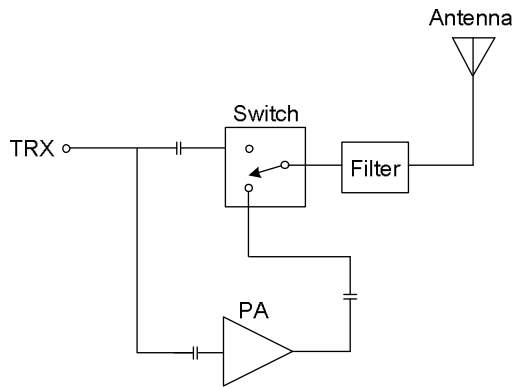

12x18x0.6mm PCB (with BHWM253)

Features & Benefits:

- 4-in-1 2.4GHz RF Front-End Solution: PA, Switch, Harmonic Filters and Antenna in Compact, 12x18mm PCBA
- Innovative, Patented RF Active Integrated Antenna (RFAiA™) Architecture
- Tx Power: ~13/15dBm at Vdd=3.3V/4.2V
- Low Current: ~25mA for 13dBm, ~35mA for 15dBm
- Integrated Harmonic Filters for FCC Compliance
- Comparable Antenna Efficiency to Much Larger Dipoles
- Stable Antenna VSWR; Insensitive to Housing Effects
- Minimum RF Design Requirement for Main PCB
- Simple Surface-Mount Interface to Main Product PCB
- 12x15mm Extension from Edge of Main PCB
- Simple Single-Port Interface with all 2.4GHz SoCs
- Option to Insert a 2nd BHWM253 as LNA/Switch on main PCB to Improve both Tx Power and Rx Sensitivity

BHWR250A Pinout & Application Schematic



Application Schematic

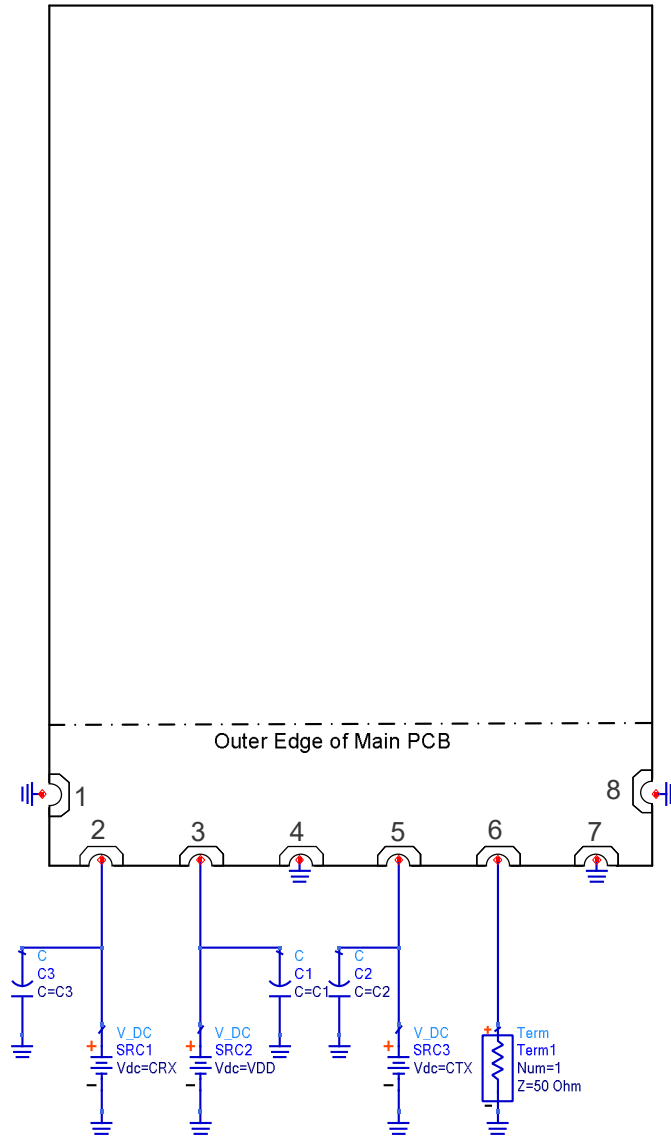

Pin Assignment

Pin Number	Pin Name	Description
2	CRX	Logic Control Voltage for Rx
3	VDD	DC Supply Voltage
5	CTX	Logic Control Voltage for Tx
6	TRX	RF Port for Interface with SoC
1,4,7,8	GND	Connect to GND on Main PCB

Logic Control Table

CTX	CRX	Mode of Operation
0	0	All Off
1	0	Transmit (PA ON)
0	1	Receive (By-Pass)

BHWR250A 2.4GHz AiA Evaluation Board



Evaluation Board

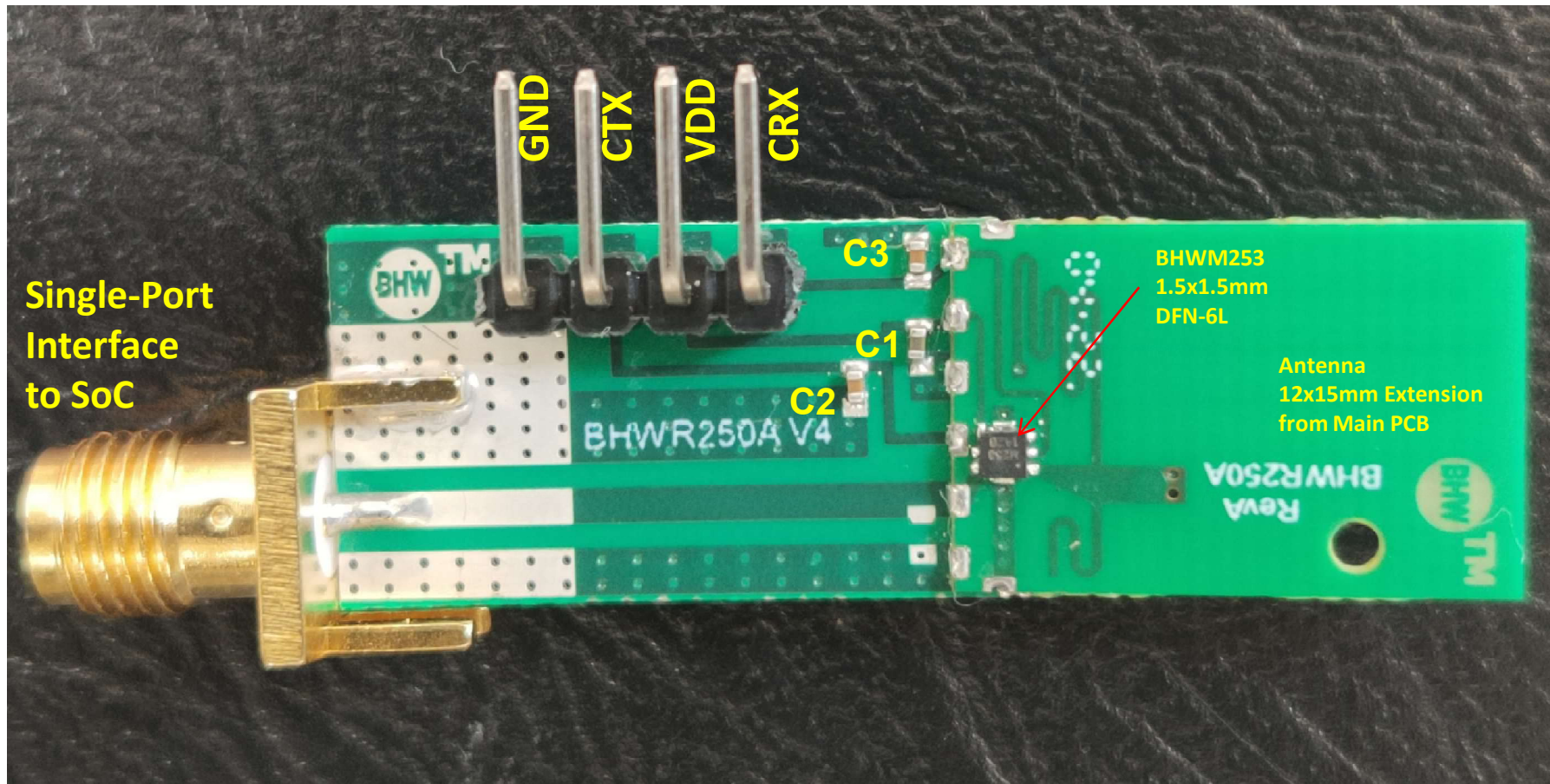

Notes:

- Only three decoupling capacitors are needed on main PCB: C1=1uF, C2=C3=1nF.
- Overlapping between BHWR250A and main PCB is 3mm nominal, but can be adjusted slightly to offset frequency shift due to PCB size, shape and cover effects.

BHWR250A VSWR for Tx Mode



Without Housing



With Housing

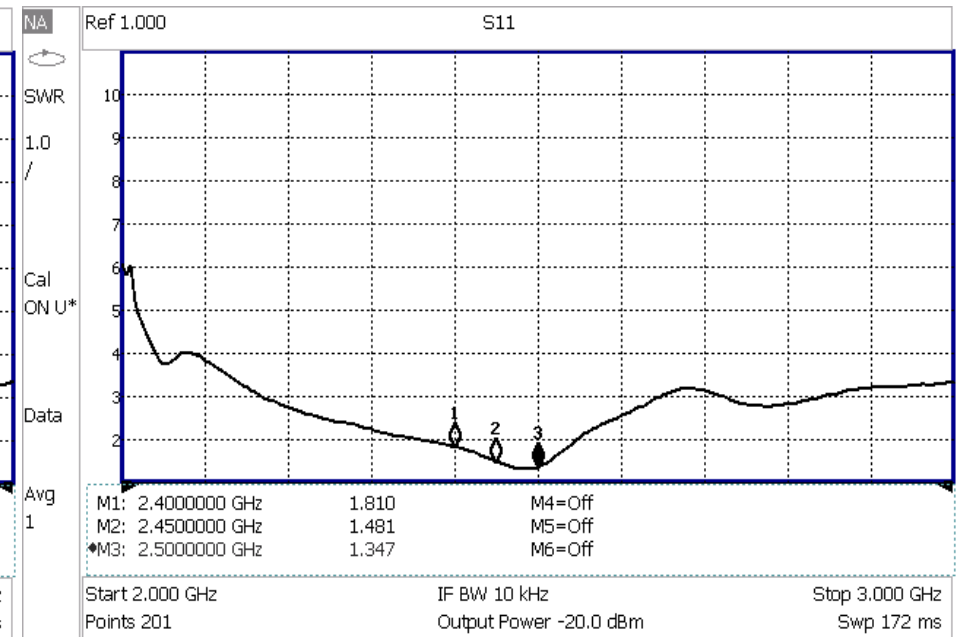
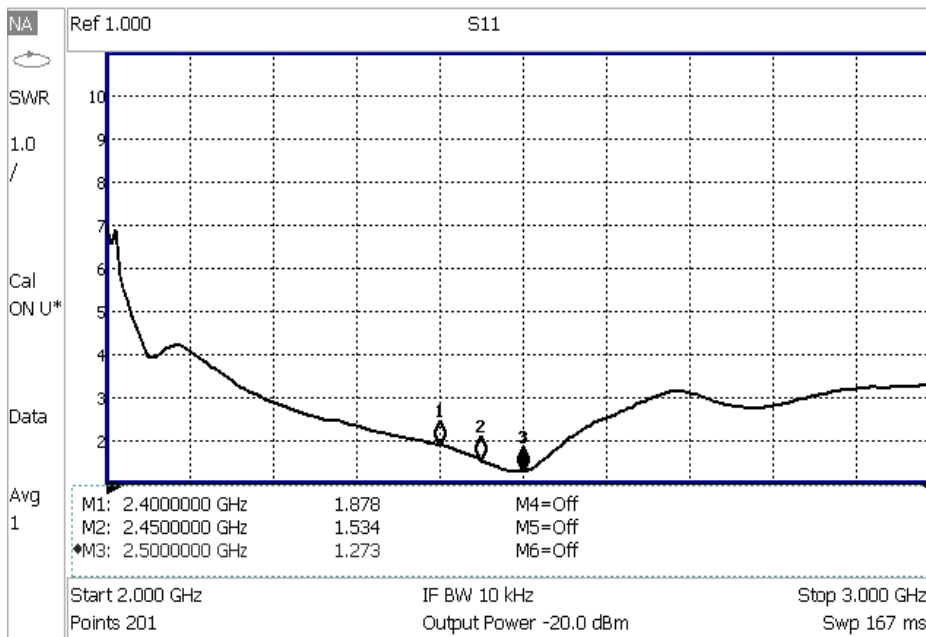

DC Bias: Vdd=CTX=3.3V, CRX=0; Vdd=1.2~4.2V Operational
Note: Measured data includes EVB feedline and SMA connectors.

BHWR250A VSWR for Rx Mode

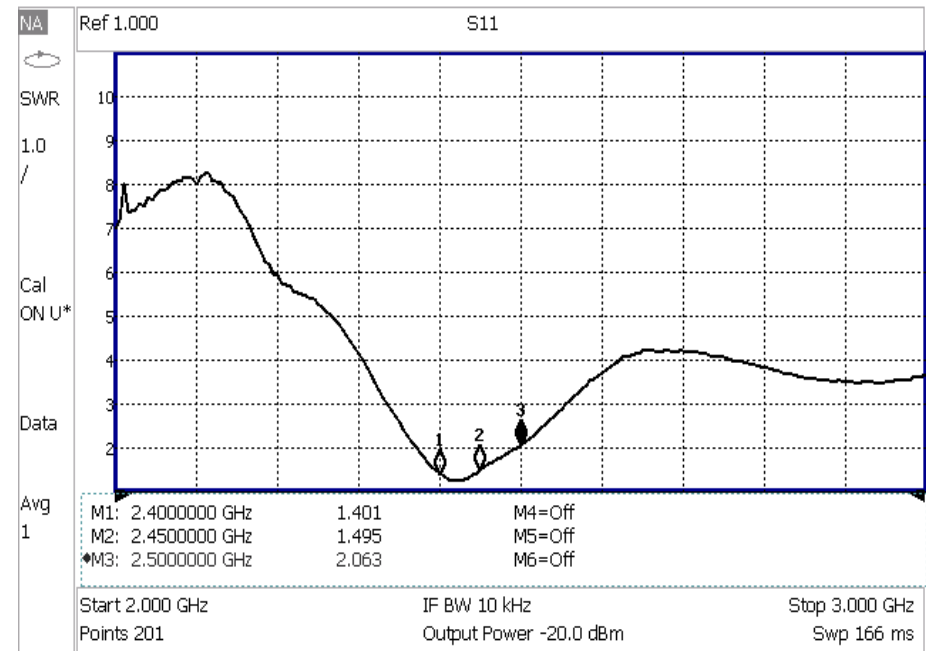
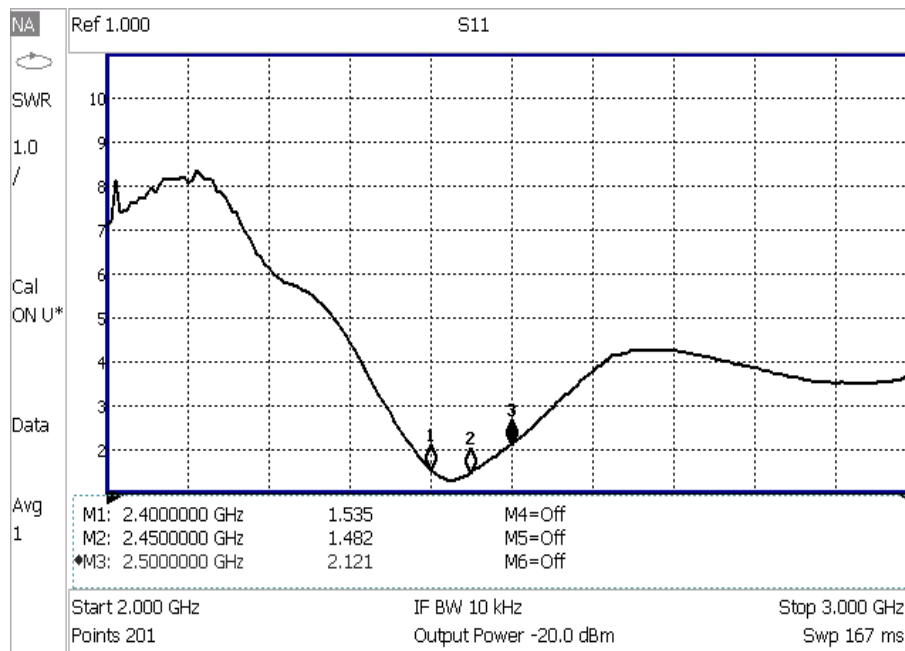
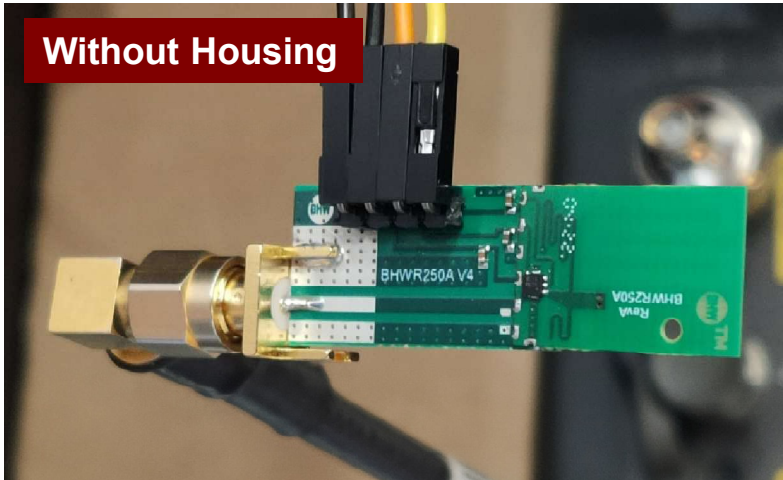

DC Bias: Vdd=CRX=3.3V, CTX=0; Vdd=1.2~4.2V Operational
Note: Measured data includes EVB feedline and SMA connectors.



Appendix 2

BHWM253 Standalone EVB Test Data (For PA Applications)

BHWM253 2.4GHz RF-FE with Common TRX Port



Functional Block Diagram

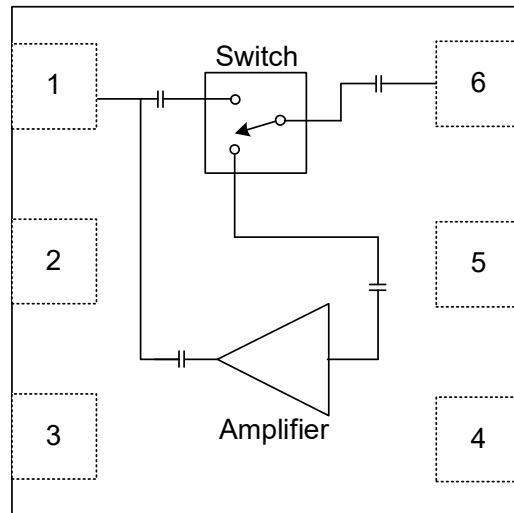

Package Pin-Out

(Top "See-Through" View)

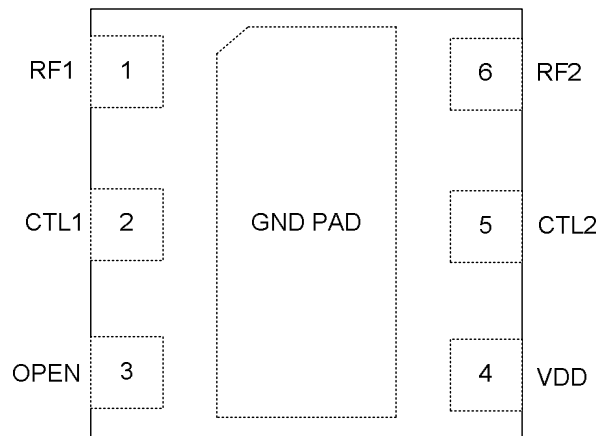

DFN-6L 1.5x1.5x0.55mm



Product Overview:

- Advanced GaAs E/D-pHEMT Process
- 2.4-2.5GHz Operation
- Operation Voltage: 1.2~4.2V
- Bias Current: 3~16mA over 1.2~3.6V Control Voltage
- Rx Noise Figure: 1.8~2dB; Rx Gain: 10~13dB
- IIP3: ~+5.5dBm at VDD=3.3V
- Switch Insertion Loss: ~1.3dB
- Amplifier Can Be Used as either LNA or PA
- Amplifier Output Power: ~13dBm at 3.3V/25mA
- Amplifier Output Power: ~15dBm at 4.2V/35mA
- Common Tx/Rx Port Fully Matched to 50 Ohm
- Simplest BOM: Needs Only 1 Capacitor
- ESD on All I/O Pins: 600V HBM RF; 1KV Non-RF
- Ultra-Small 1.5x1.5mm DFN Package

Applications:

- Bluetooth/ZigBee/Wi-Fi IoT Solutions
- Bluetooth/BLE Audio & Video
- Smart Watches and Wearables
- BLE AoA/AoD Direction Finding & Indoor Location
- Remote Control for Gaming, Toys, Drones
- Home Automation
- Electronic Labeling, Asset Tracking
- Other Generic 2.4GHz Radio Designs

BHWM253 EVB for PA Application



Connection for Using BHWM253 as PA with By-Pass for Receive

Application Schematic

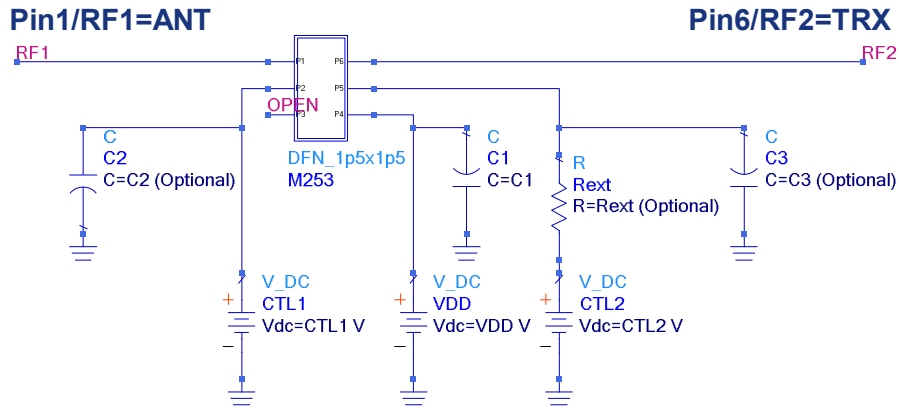

Logic Control (For PA Application)

CTL1 (Pin 2)	CTL2 (Pin 5)	Mode of Operation
0	0	All Off
0	1	Transmit (PA On)
1	0	Receive (By-Pass)

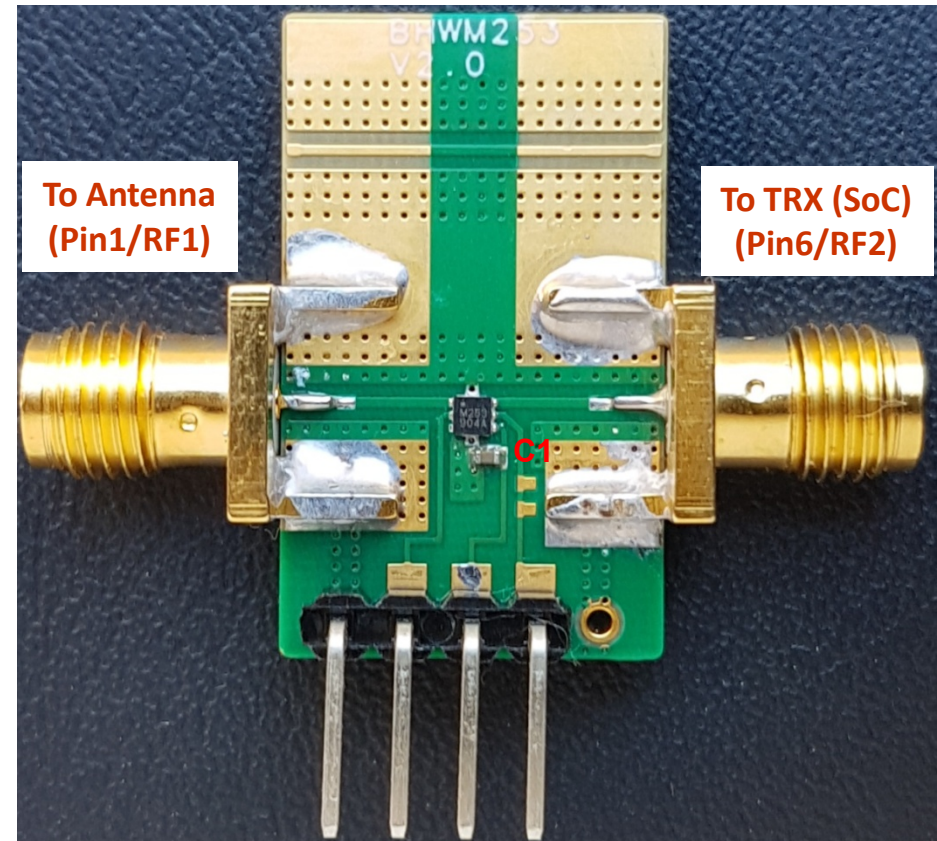

GND
CTL1
VDD
CTL2

Notes:

- BOM: C1=1uF, C2=C3=1nF
- Recommended VDD: 1.8~4.2V
- Place C1 for VDD right next to Pin4; Location of C2 & C3 for CTL1, CTL2 are less critical
- External resistor Rext can be used to further reduce current consumption for certain low-power applications

S-Parameters at VDD=3.3V, CTL2=3.3V, CTL1=0

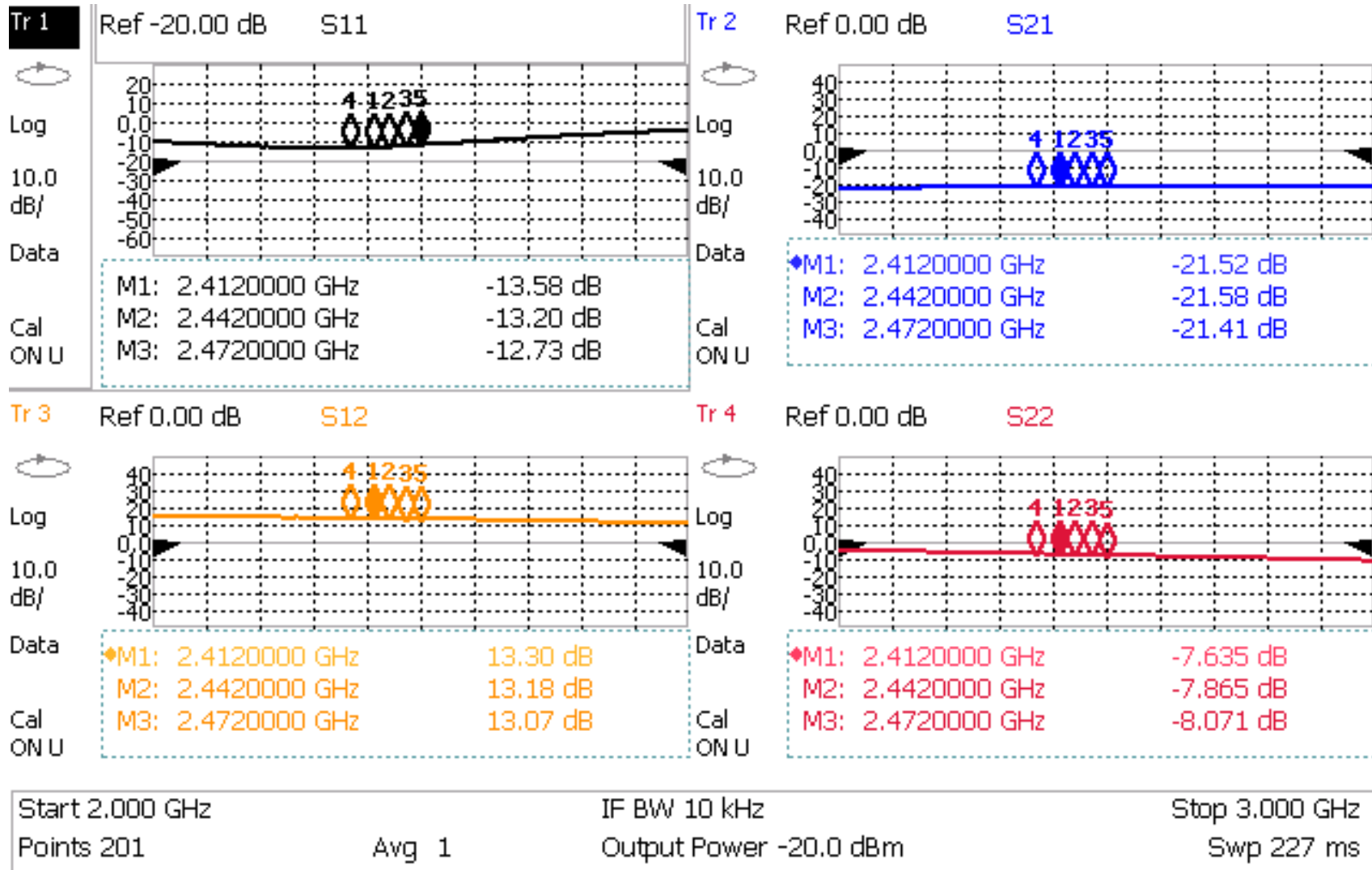

Note:

-DC bias: VDD=3.3V, CTL2=3.3V, CTL1=0

-EVB and SMA connector losses de-embedded with THRU calibration

S-Parameters at VDD=3.3V, CTL2=0V, CTL1=3.3V

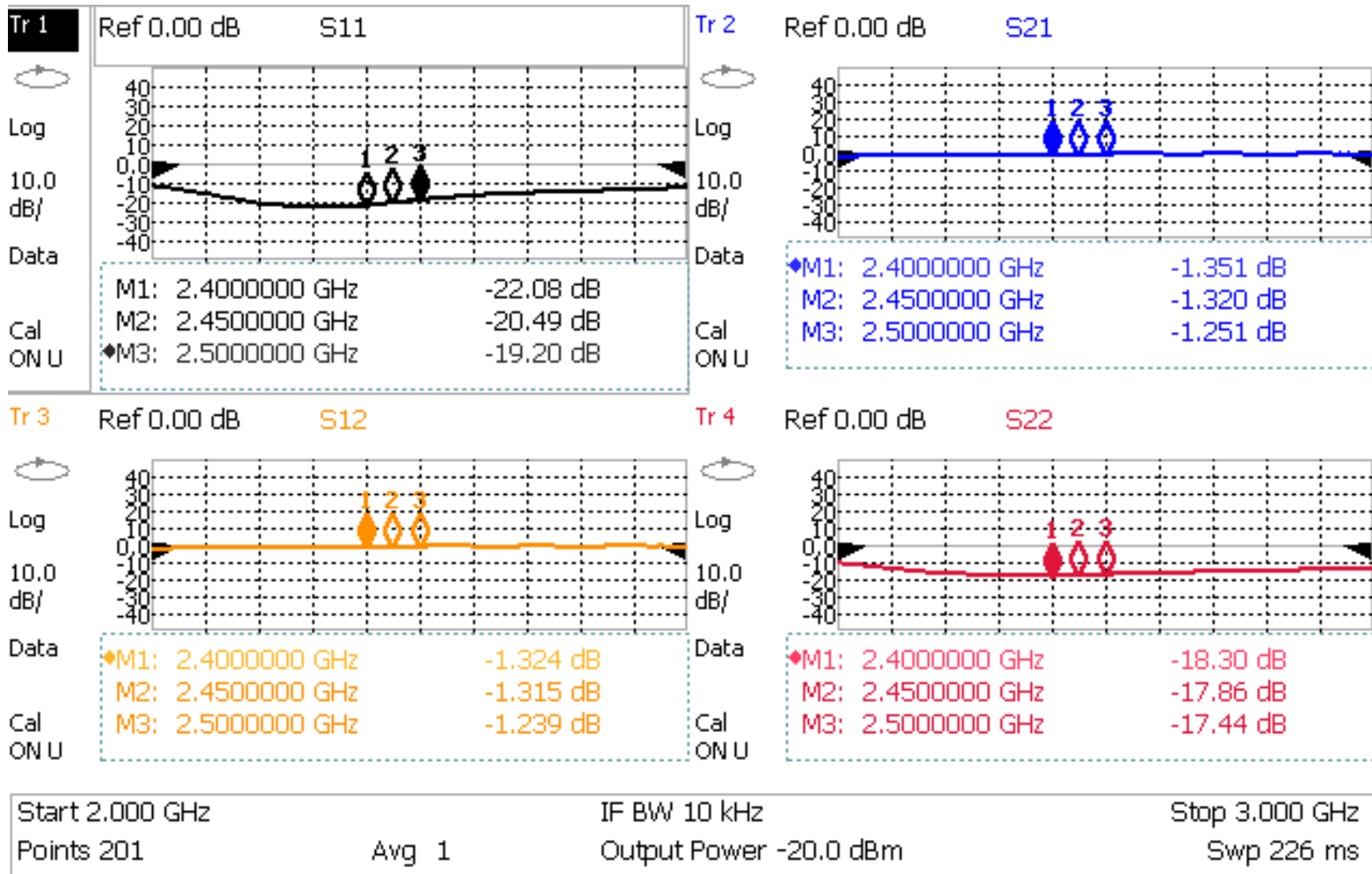

Note:

-DC bias: VDD=3.3V, CTL2=0V, CTL1=3.3V

-EVB and SMA connector losses de-embedded with THRU calibration

Small-Signal Gain vs Control Voltage CTL2

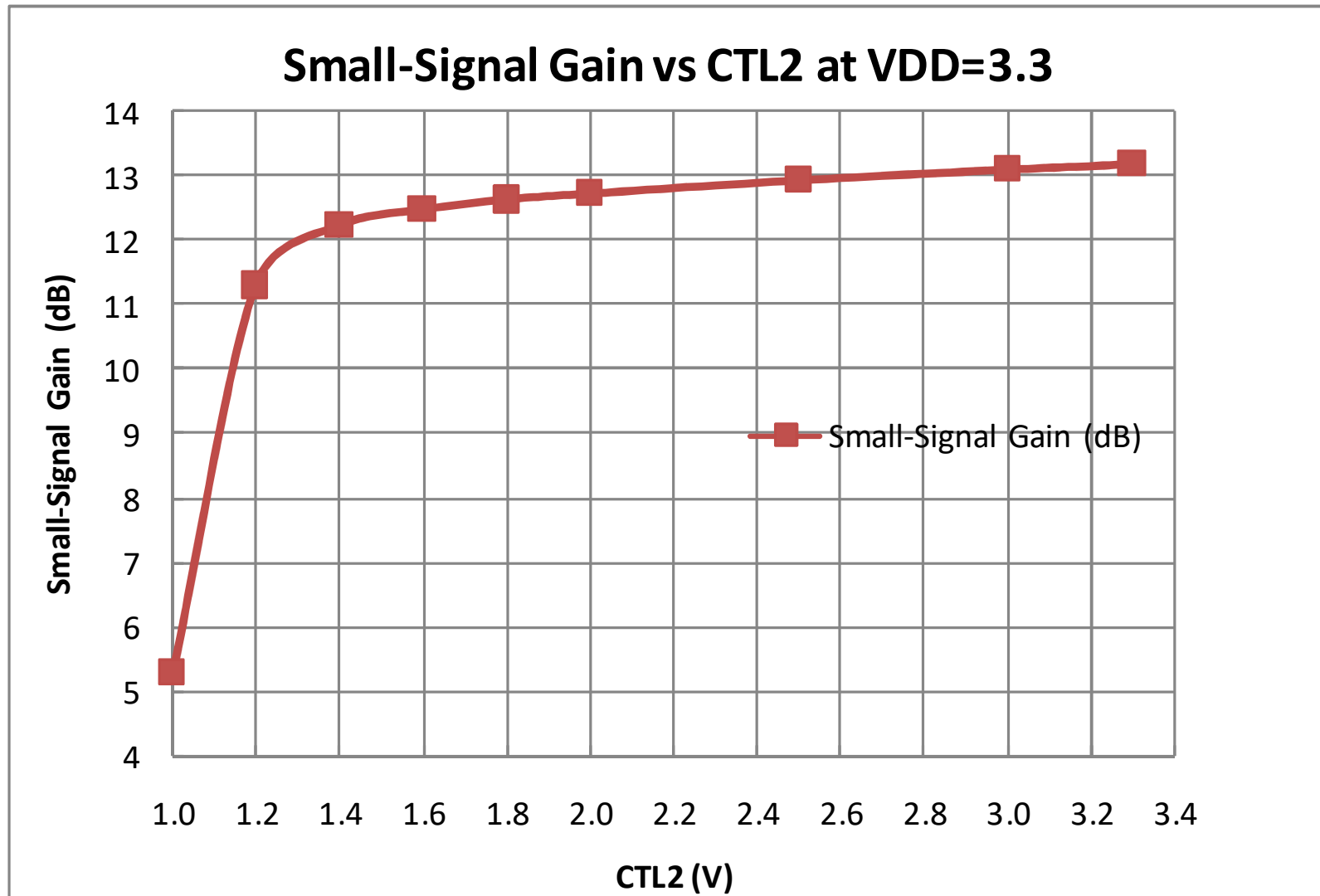

Note:

-DC bias: VDD=3.3V, CTL1=0V, CTL2=Various

-EVB and SMA connector losses de-embedded with THRU calibration

CW Power Sweep at VDD=3.3V, CTL2=3.3V



Freq.=2.45GHz, VDD=3.3V, CTL2=3.3V, CTL1=0

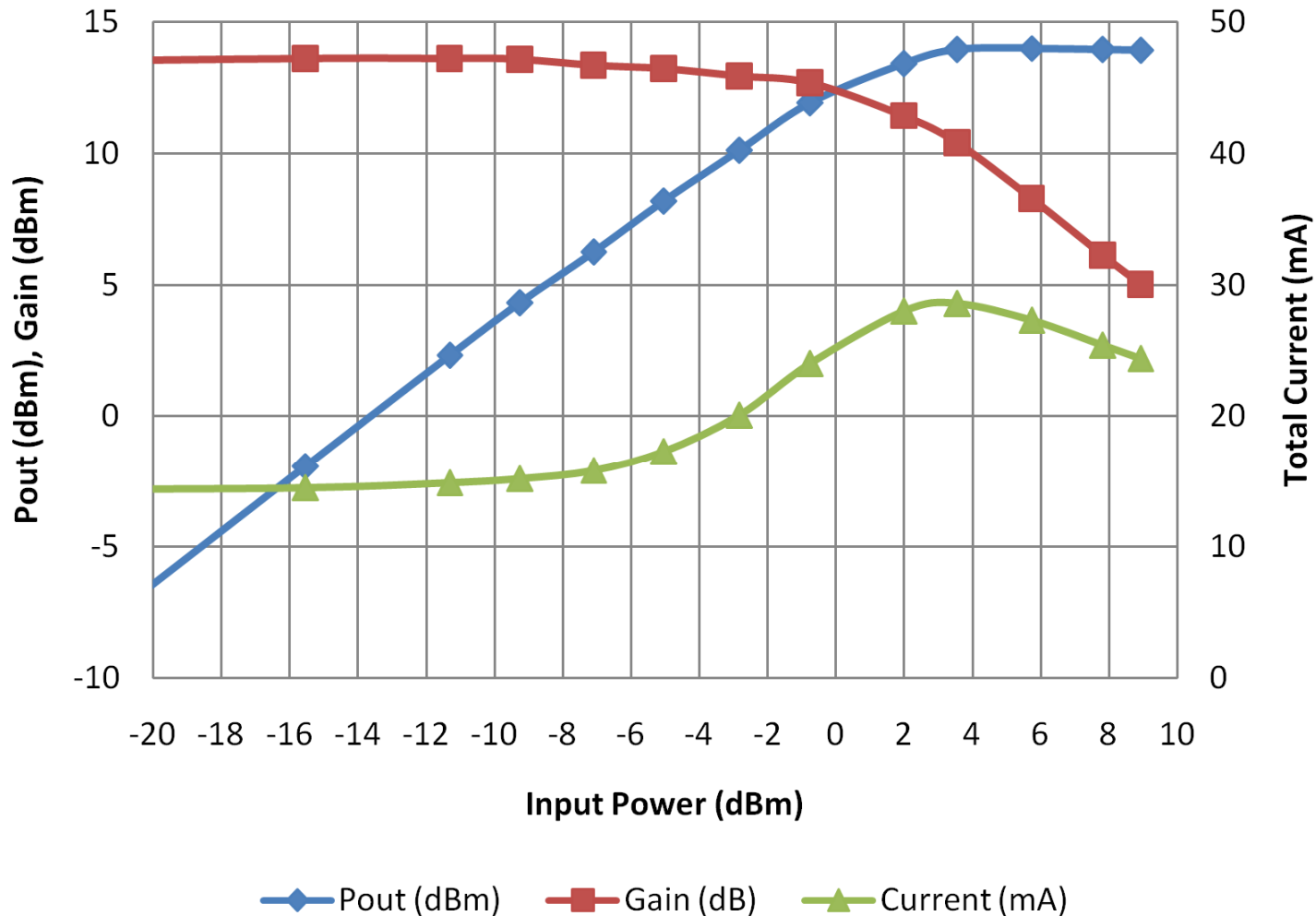

Notes:

-VDD=3.3V, CTL2=3.3V, CTL1=0V

-SMA connector and EVB trace losses were de-embedded (0.2dB offset)

CW Power Sweep at VDD=4.2V, CTL2=1.8V



Freq.=2.45GHz, VDD=4.2V, CTL2=1.8V, CTL1=0

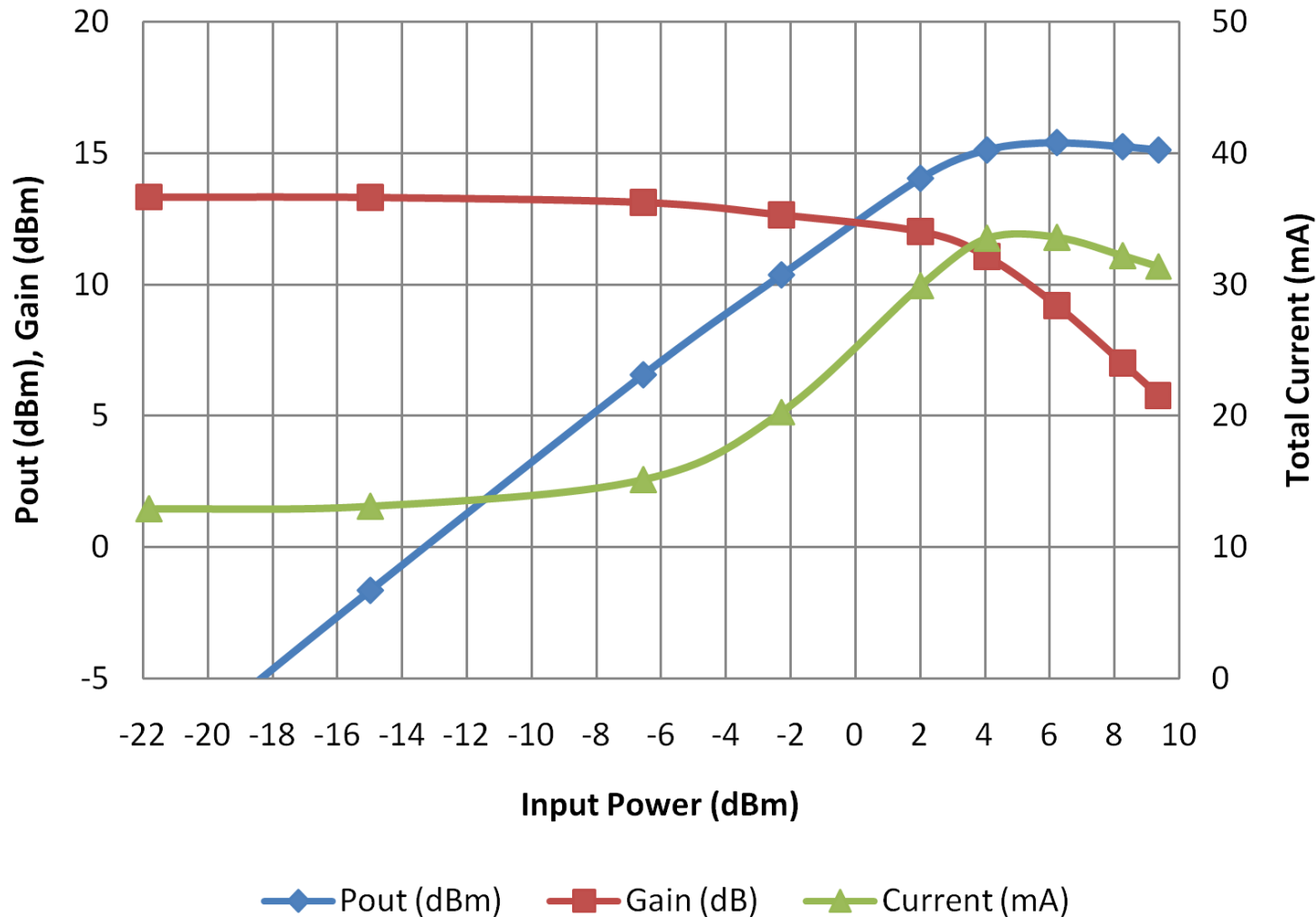

Notes:

-VDD=4.2V, CTL2=1.8V, CTL1=0

-SMA connector and EVB trace losses were de-embedded (0.2dB offset)

Output Power vs Pin & Control Voltage CTL2



Pout vs Pin & CTL2 at VDD=3.3V

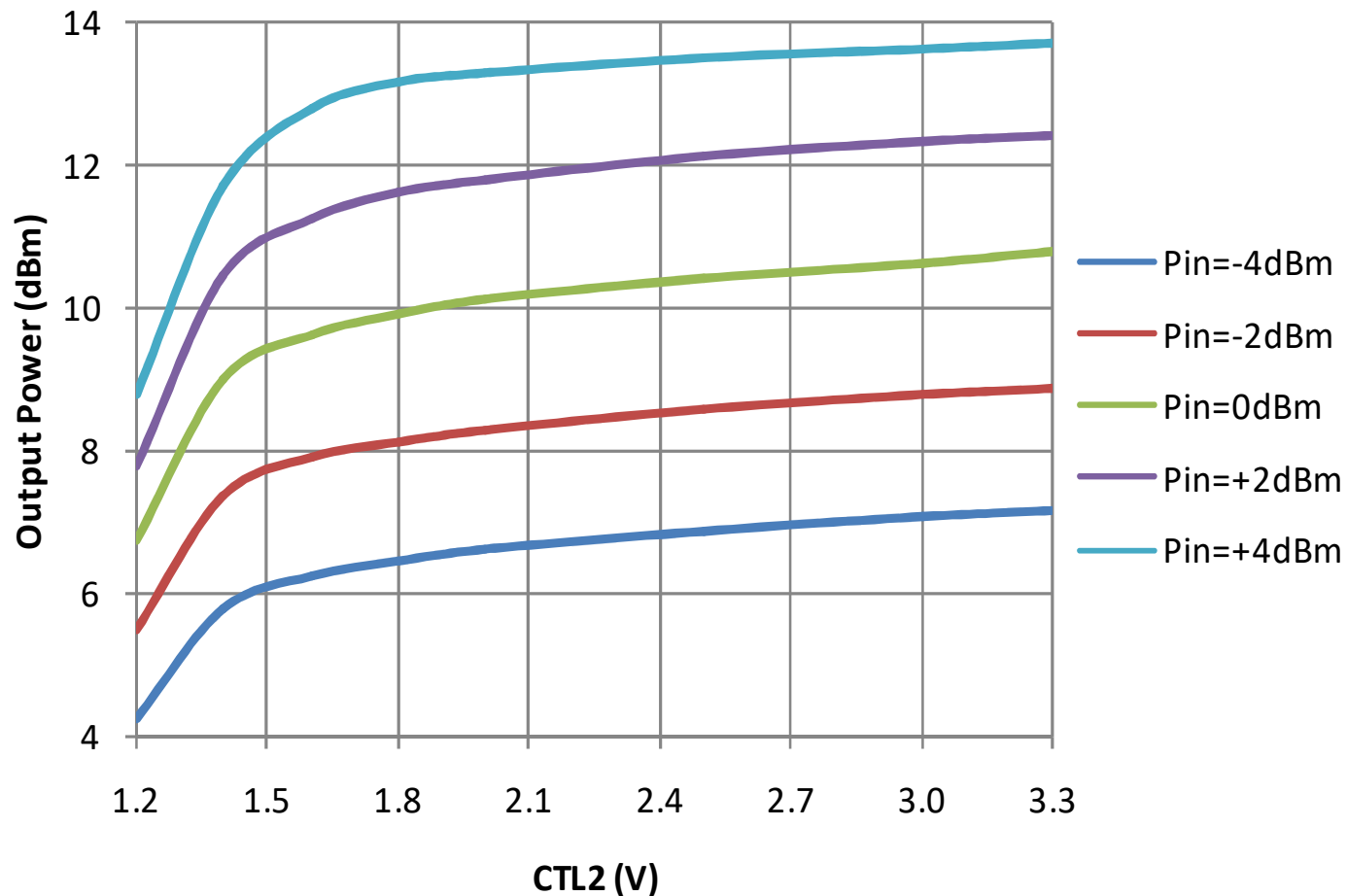

Notes:

-VDD=3.3V (fixed), CTL2=1.2~3.3V, CTL1=0

-Measured output power included SMA connector and EVB trace losses (~0.2dB)

BHW RF Front-End Solutions AppNote Library



In addition to standard datasheets and EVB/BOM info, BHW publishes an AppNote series that address various topics on RF front-end design and performance over a wide frequency range from 300MHz to 6GHz, as an effort to assist customers in developing cutting-edge, cost-competitive products:

- BHW AppNote #001 - Cross-Over Cascade of BHWM253 to Boost Tx Power and Rx Sensitivity of 2.4GHz Systems
- BHW AppNote #002 - Accurate Benchmark of GNSS CNO Using the Power-Splitter Method
- BHW AppNote #003 - Boosting Wi-Fi Tx Power and Rx Sensitivity with BHWA251 and BHWM252
- BHW AppNote #004 - UHF 900MHz RF Front-End Solution Using BHWA251 Half-Watt PA and BHWL160 Sub-1dB-NF LNA
- BHW AppNote #005 - Sub-1GHz Applications of BHWA350 2-in-1 Wideband Fully Matched Amplifier
- BHW AppNote #006 - Low-Noise High-IIP3 LNB Architecture for Dual-Band High-Precision GNSS Using Cascade of BHWL160
- BHW AppNote #007 - UWB RF Front-End Solution Using BHWA350 and BHWM552
- BHW AppNote #008 - High-Power 5.8GHz RF Front-End Solution Using BHWA555 and BHWM552 for ETC, V2X and Wireless Video
- BHW AppNote #009 - 5.8GHz RF Front-End Using BHWA350 and BHWM552 for Wireless Audio
- BHW AppNote #010 - Multi-Constellation GNSS Active Antenna Using BHWL161 Cascade and Single-Fed Dual-Band Antenna
- BHW AppNote #011 - BHWL161 Super-Compact Low-Power Low Noise Amplifier for Range Extension of 2.4GHz RC and IoT
- BHW AppNote #012 - Enabling Cost-Effective High-Precision GNSS Using BHWL161 and Linear-Polarization PCB Antenna
- BHW AppNote #013 - Improving the Quality of Wireless Connectivity for 2.4GHz Audio and IoT with BHWM257 Compact FEM
- BHW AppNote #014 - Designing Ultra Low-Power High-Performance GNSS Products Using BHWL160 GaAs PHEMT LNA
- BHW AppNote #015 - BHWL161 GNSS Full-Band High-Performance LNA in Super-Compact 1x1mm DFN with Relaxed Pin Pitch
- BHW AppNote #016 - Improving GNSS NF Measurement Accuracy Using Broadband LNA BHWL161 as Pre-Amp
- BHW AppNote #017 - High-Efficiency, Low-NF 2.4GHz Front-End Solution for IoT Using BHWA251 and BHWM252
- BHW AppNote #018 - Optimizing BHWA555 Wideband One-Watt PA for Long-Range 5.8GHz Transmitter Applications
- BHW AppNote #019 - Miniature 2.4GHz RF Front-End with Integrated Chip Antenna and BHWM253 for TWS and IoT
- BHW AppNote #020 - Multiplying the Range for 2.4GHz Music Streaming with BHWR250L Active Integrated Antenna (AiA)
- BHW AppNote #021 - Range Extension for 2.4GHz Wireless Systems with BHWR250M Active Integrated Antenna (AiA)
- BHW AppNote #022 - Enabling Long-Range Angle-of-Arrival for High-Precision Indoor Positioning with BHWR250N RF AiA
- BHW AppNote #023 - Extend the Range for 5.8GHz Audio/Video Streaming with BHWR580M Active Integrated Antenna (AiA)
- BHW AppNote #024 - Improving 5.8GHz Radio Link Budget with BHWR580L Active Integrated Antenna (AiA)
- BHW AppNote #025 - Improving Range and Throughput of 2.4GHz Wi-Fi with BHWR250 Array Antenna
- BHW AppNote #026 - Improving Range and Throughput of 5GHz Wi-Fi with BHWR550 Array Antenna
- BHW AppNote #027 – Coin-Cell and Batteryless 1km Long Range NanoBeacon with BHWR250A AiA and Energy Harvesting
- BHW AppNote #028 - Use BHWM252 Cascade to Extend Range of 2.4GHz Wireless Systems with Single-Port SoCs
- BHW AppNote #029 - Improving Range of 2.4GHz Wireless Microphones and Audio Systems with BHWR250A Active Integrated Antenna (AiA)
- BHW AppNote #030 - Simultaneous Improvement in Range and Battery Life of 2.4GHz Wireless Systems with BHWR250M AiA

Contact support@bhwtechnologies.com or BHW distributors/representatives for your copy of the above and new up-coming documents.