



Wideband 4-6GHz GaAs RF Front-End with LNA and Switch

Description

BHWM552 is an RF Front-End IC in advanced GaAs E/D-PHEMT process that integrates a low noise amplifier and SPDT switch for operation over a wide frequency range from around 4GHz to over 6GHz. The device features on-chip impedance match for all RF ports (5GHz band), and is offered in an ultra-compact, 6-Lead DFN (Dual Flat No-Lead) package. It has integrated ESD protection circuits on all I/O ports.

Key Features

- Advanced GaAs E/D PHEMT Process
- 4-6GHz Operation Frequency Range
- Fully Matched RF Ports
- Low Tx Insertion Loss: 0.8dB
- Low NF: 1.7dB at 5.5GHz
- Rx Gain: 10dB at 5.5GHz
- Low LNA Current: 12mA
- Integrated ESD Protection
- Ultra-Small 1.5x1.5mm DFN Package

Key Applications

- Wi-Fi IEEE 802.11ax/ac/n/a Systems
- Ultra-Wide Band (UWB) Systems
- Electronic Toll Collection (ETC) Systems
- UAV/Drones
- 5.8GHz Wireless Audio/Video
- Remote Control
- Generic 5GHz TDD Radio Designs

Functional Block and Package Information

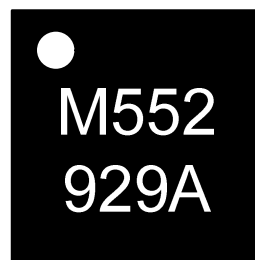
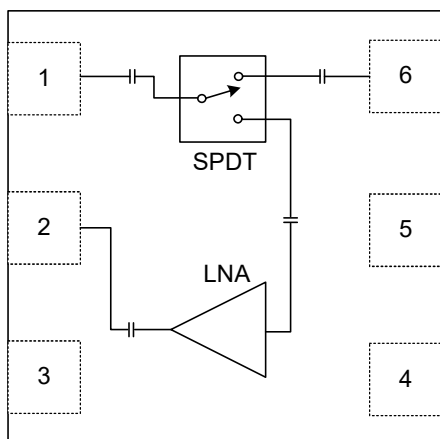

1.5x1.5x0.55mm 6L DFN



Wideband 4-6GHz GaAs RF Front-End with LNA and Switch

Pin Assignment and Pin Description

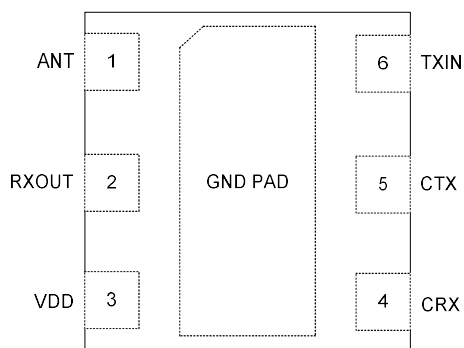

(Top "See-Through" View)

Pin Number	Pin Name	Description
1	Ant	Antenna Port
2	RXOUT	LNA Output
3	VDD	DC Supply Voltage for the LNA
4	CRX	Control Voltage for Rx Mode
5	CTX	Control Voltage for Tx Mode
6	TXIN	Tx Input to Antenna

Absolute Maximum Ratings

Parameter	Rating	Unit
Maximum Supply Voltage	5	V
Maximum Bias Voltage	3.6	V
Maximum Supply Current	50	mA
Maximum Input Power	+10	dBm
Junction Temperature	+150	°C
Operation Temperature	-40 to +85	°C
Storage Temperature	-40 to +150	°C
Moisture Sensitivity Level	MSL1	

Note: Do not exceed any single or combination of the above parameters. Sustained operation at or above the Absolute Maximum Ratings may result in permanent damage to the device. Maximum Input Power Rating assumes 50-Ohm load impedance.



Wideband 4-6GHz GaAs RF Front-End with LNA and Switch

Electrical Specifications: Receive (ANT to RXOUT)*

Parameter	Condition	Specification			Unit
		Min.	Typ.	Max.	
Operating Frequency		4		6	GHz
Operating Voltage		1.5	3.3	3.6	V
Quiescent Current	VDD=CRX=3.3V, No RF Input		12		mA
Small-Signal Gain	5.5GHz, Pin=-30dBm		10		dB
Shutdown Current	VDD=3.3V, CRX=0V		0.3		uA
Noise Figure	5.15-5.85GHz		1.7	2	dB
Input P1dB			+3		dBm
Input Return Loss			10		dB
Output Return Loss			10		dB
Isolation			17		dB

*Refer to BHWM552 Application Note for additional test data in details.

Electrical Specifications: Transmit (TXIN to ANT)*

Parameter	Condition	Specification			Unit
		Min.	Typ.	Max.	
Operating Frequency		4		6	GHz
Operating Voltage		1.5	3.3	3.6	V
Insertion Loss	VDD=CTX=3.3V		0.8		dB
Input P1dB			25		dBm
Input Return Loss			15		dB
Output Return Loss			12		dB
Isolation			25		dB

*Refer to BHWM552 Application Note for additional test data in details.



Wideband 4-6GHz GaAs RF Front-End with LNA and Switch

Logic Control

CTX (Pin 5)	CRX (Pin 4)	Mode of Operation
0	0	All Off
1	0	Transmit
0	1	Receive

Application Schematic

(Refer to BHWM552 Application Note for Details)

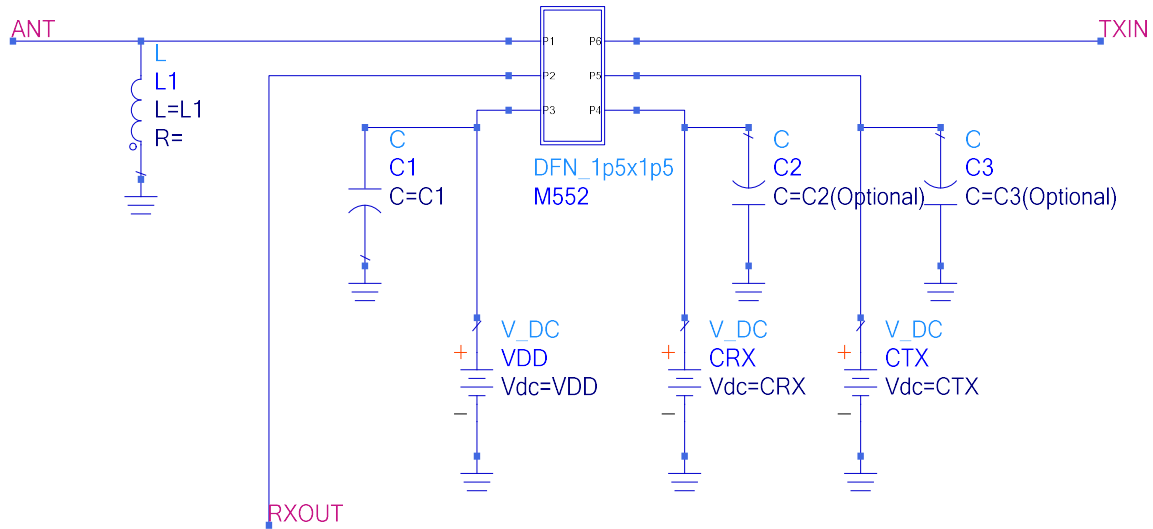



Wideband 4-6GHz GaAs RF Front-End with LNA and Switch

Package Drawing and Dimensions

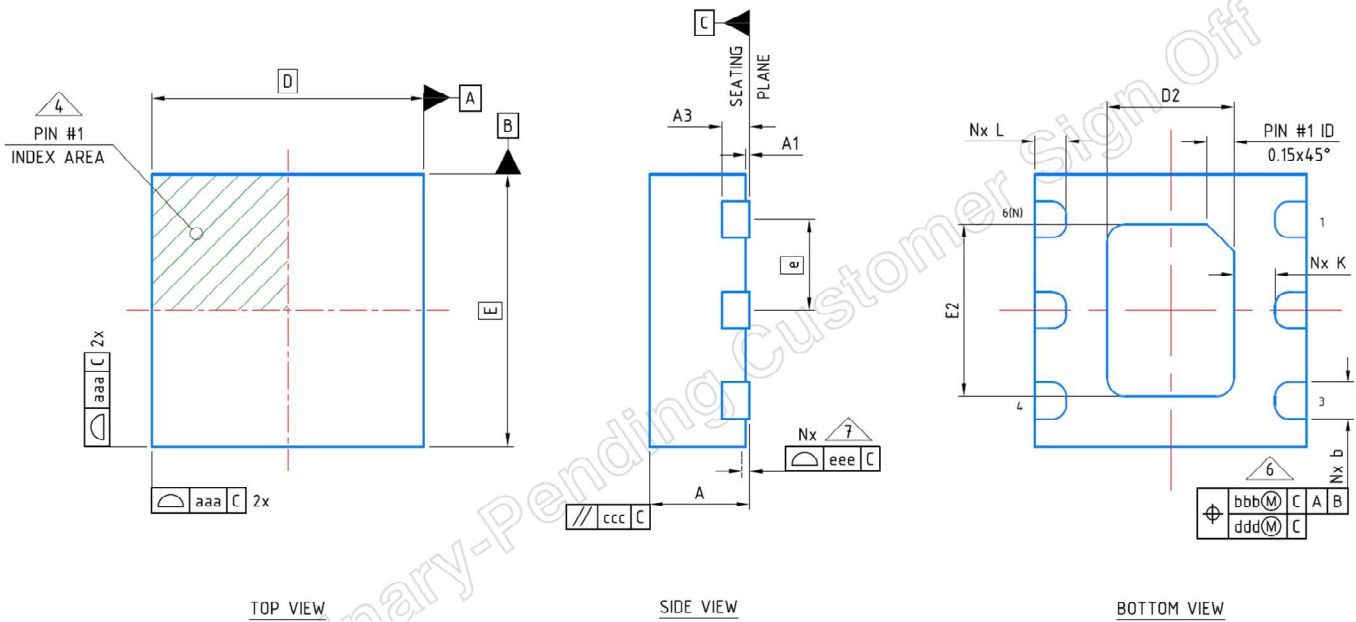

Dimension Table				
Thickness Symbol	UT			NOTE
	MINIMUM	NOMINAL	MAXIMUM	
A	0.51	0.55	0.60	
A1	0.00	0.02	0.05	
A3	---	0.15 Ref	---	
b	0.15	0.20	0.25	6
D	1.50 BSC			
E	1.50 BSC			
e	0.50 BSC			
D2	0.55	0.70	0.80	
E2	0.80	0.95	1.05	
K	0.15	---	---	
L	0.125	0.175	0.225	
aaa	0.05			
bbb	0.10			
ccc	0.10			
ddd	0.05			
eee	0.08			
N	6			3
NE	3			5
NOTES	1, 2			
LF PART NO.	443896			
LF DWG. NO.	CARSEM-HDS-043 Rev. A			

NOTE:

1. Dimensioning and tolerancing conform to ASME Y14.5-2009.
2. All dimensions are in millimeters.
3. N is the total number of terminals.
4. The location of the marked terminal #1 identifier is within the hatched area.
5. NE refers to the maximum number of terminals on E side.
6. Dimension b applies to the metalized terminal. If the terminal has a radius on the end of it, dimension b should not be measured in that radius area.
7. Coplanarity applies to the terminals and all other bottom surface metalization.



Wideband 4-6GHz GaAs RF Front-End with LNA and Switch

Package Marking



← Line 1: Pin 1 Indicator

← Line 2: Part Number, M552

← Line 3: Datecode, YWWA

Date Code Description

Y: Year Code (e.g, 9 for 2019)

WW: Working Week (01~52)

A: Revision Code (Default=A)