



Wideband 0.6-2GHz GaAs Low Noise Amplifier

Description

BHWL160 is an ultra-low noise amplifier designed in advanced GaAs E/D-pHEMT process, featuring wideband operation from 600MHz to 2GHz. For GNSS, it provides simultaneous, uncompromised performance across all frequency bands of all major constellations including GPS, Beidou, Galileo, NavIC and GLONASS from 1176 to 1610MHz with a single, simple matching network. The device is housed in an ultra-compact 1.45x1mm 6-Lead DFN (Dual Flat No-Lead) package, provides 0.5dB noise figure (GNSS High-Band), and the industry's highest-class input P1dB and IIP3/IIP2, with adjustable current as low as sub-2mA for 1.2V to 3.6V operation. BHWL160 has integrated ESD protection on all pins, and requires only one external inductor and capacitor for conventional GNSS bands from 1550 to 1610MHz.

Key Features

- Advanced GaAs E/D-pHEMT Process
- 0.6-2GHz Operation Frequency Range
- Low Noise Figure: 0.5~0.7dB (GNSS Full Band)
- Power Gain: 15/16dB (High/Low-Band)
- High Input P1dB: -6dBm at 1575MHz
- Low Current: 6mA at 3.3V
- Adjustable Current 1.5~7mA at 1.2~3.6V
- Integrated ESD for 1KV HBM & >2KV CDM
- Ultra-Small 1.45x1mm DFN Package

Key Applications

- GNSS for Smart Watches, Wearables
- GNSS for PNDs, Drones/UAVs
- GNSS for Vehicles, ADS Systems
- UHF 600/700/868/915MHz Systems
- 2.4GHz Remote Controls
- 2.4GHz Angle-of-Arrival Solutions
- Other Generic Radios from Sub-GHz to 2.5GHz

Functional Block and Package Information

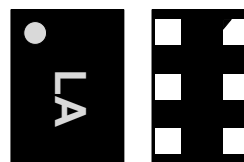
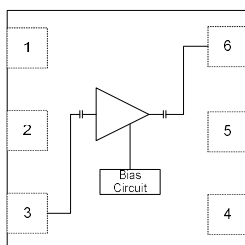

1.45x1x0.55mm 6L DFN



Wideband 0.6-2GHz GaAs Low Noise Amplifier

Pin Assignment and Pin Description

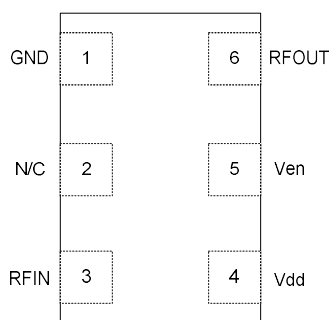

(Top "See-Through" View)

Pin Number	Pin Name	Description
1	GND	Ground
2	N/C	No Connection. Can be connected to GND in PCB layout.
3	RFIN	RF Input
4	Vdd	DC Voltage Supply
5	Ven	LNA Enable Voltage
6	RFOUT	RF Output

Absolute Maximum Ratings

Parameter		Rating	Unit
Supply Voltage	Vdd	5	V
Enable Voltage	Ven	3.6	V
Maximum Input Power		+10	dBm
Maximum Current		25	mA
Junction Temperature		+150	°C
Operation Temperature		-40 to +85	°C
Storage Temperature		-40 to +150	°C
Moisture Sensitivity Level		MSL1	

Note: Do not exceed any single or combination of the above parameters. Sustained operation at or above the Absolute Maximum Ratings may result in permanent damage to the device. Maximum Input Power Rating assumes 50-Ohm load impedance.



Wideband 0.6-2GHz GaAs Low Noise Amplifier

Electrical Specifications (GNSS Full-Band)*

Parameter	Condition	Specification			Unit
		Min.	Typ.	Max.	
Operating Frequency		1165	1575	1610	MHz
Operating Voltage		1.2	3.3	3.6	V
Quiescent Current	VDD=VEN=3.3V, No RF Input	3.7	6	8	mA
Shutdown Current	VDD=3.3V, VEN=0		0.3		uA
Small-Signal Gain	Low-Band, Pin=-30dBm		16		dB
Small-Signal Gain	High-Band, Pin=-30dBm		15		dB
Noise Figure			0.7		dB
Input Return Loss			10		dBm
Output Return Loss			10		dB
Isolation			24		dB
Input P1dB	At VDD=VEN=3.3V		-6		dBm
IIP3 (Low-Band)	f1/f2=1176/1177MHz, -30dBm per Tone, 3.3V		+2		dBm
IIP3 (High-Band)	f1/f2=1575/1576MHz, -30dBm per Tone, 3.3V		+3		dBm

*Refer to BHWL160 Application Note for additional test data in details.

Application Schematic and Evaluation Board (GNSS Full-Band)

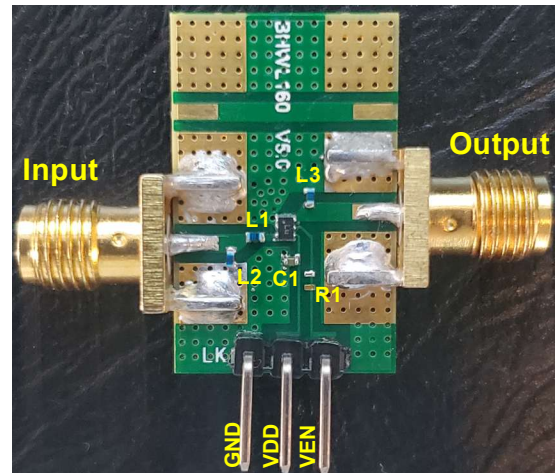
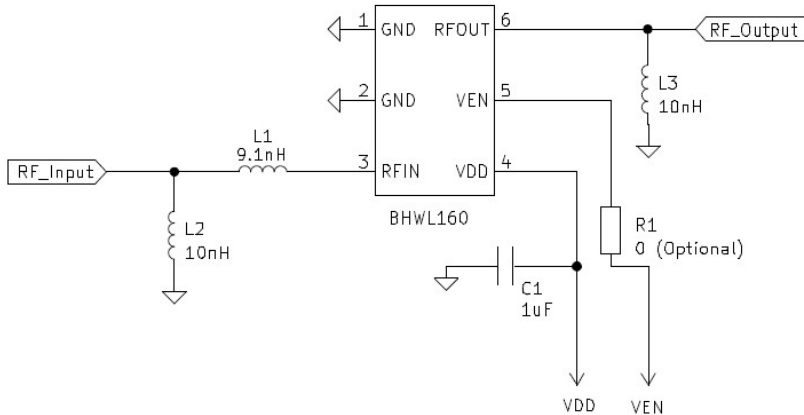



Wideband 0.6-2GHz GaAs Low Noise Amplifier

RF Characteristics (GNSS Full-Band)

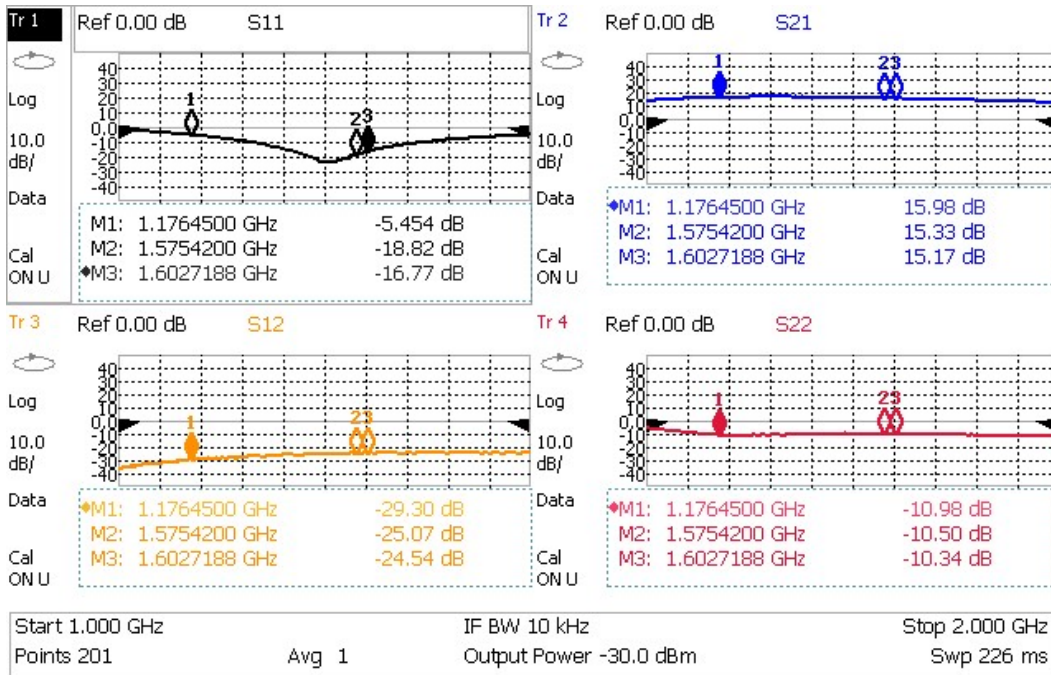

Typical Small-Signal S-Parameters at Vdd=Ven=3.3V, Pin=-30dBm

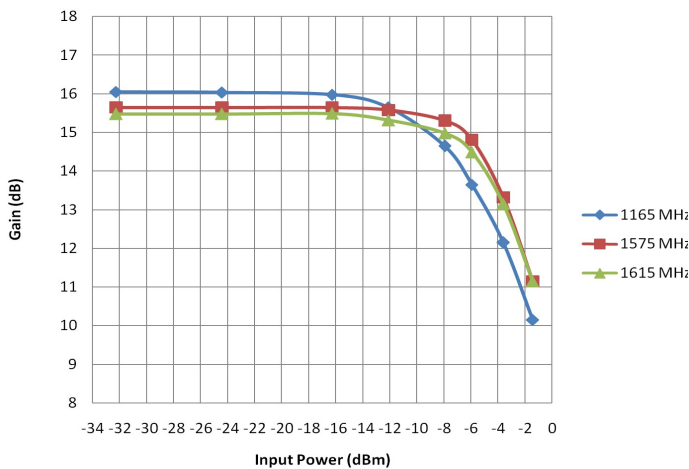

Typical Power Gain vs Pin & Frequency

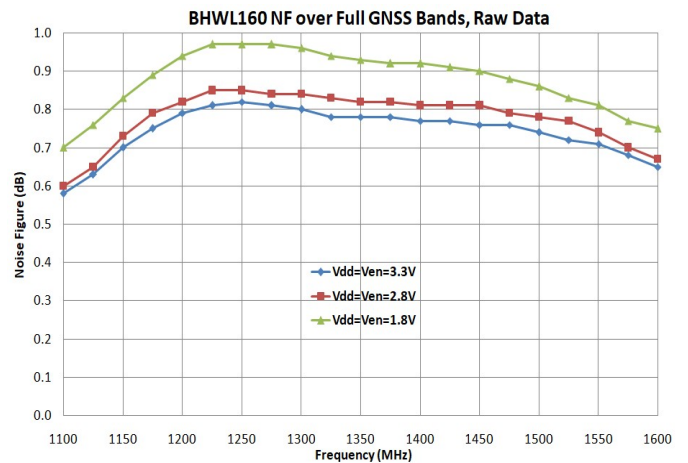

Typical Noise Figure over Fullband at Different Vdd/Ven



Wideband 0.6-2GHz GaAs Low Noise Amplifier

Electrical Specifications (GNSS High-Band)*

Parameter	Condition	Specification			Unit
		Min.	Typ.	Max.	
Operating Frequency		1550	1575	1610	MHz
Operating Voltage		1.2	3.3	3.6	V
Quiescent Current	VDD=VEN=3.3V, No RF Input	3.7	6	8	mA
Shutdown Current	VDD=3.3V, VEN=0		0.3		uA
Small-Signal Gain	Pin=-30dBm		15		dB
Noise Figure			0.5		dB
Input Return Loss			11		dBm
Output Return Loss			15		dB
Isolation			24		dB
Input P1dB	At VDD=VEN=3.3V		-5.5		dBm
In-Band IIP3	f1/f2=1575/1576MHz, -30dBm per Tone, 3.3V		+3		dBm
Out-of-Band IIP3	f1/f2=1712.7/1850MHz, -30dBm per Tone, 3.3V		+4		dBm

*As measured on BHWL160 EVB with 9.1nH input inductor (Murata LQW15 Series), VDD=VEN=3.3V. Refer to BHWL160 Application Note for additional test data in details.

Application Schematic and Evaluation Board (GNSS High-Band)

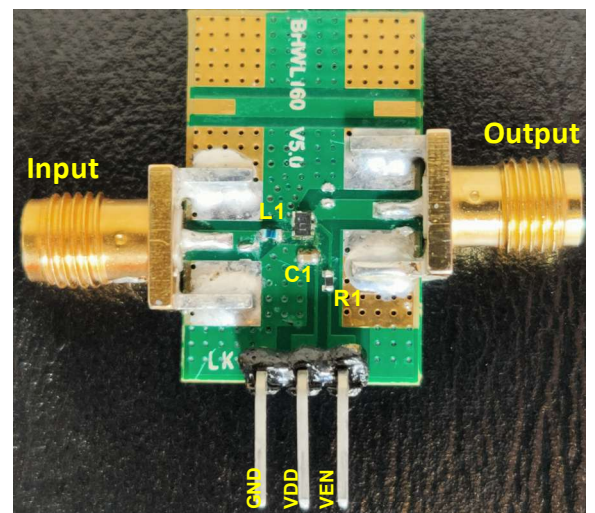
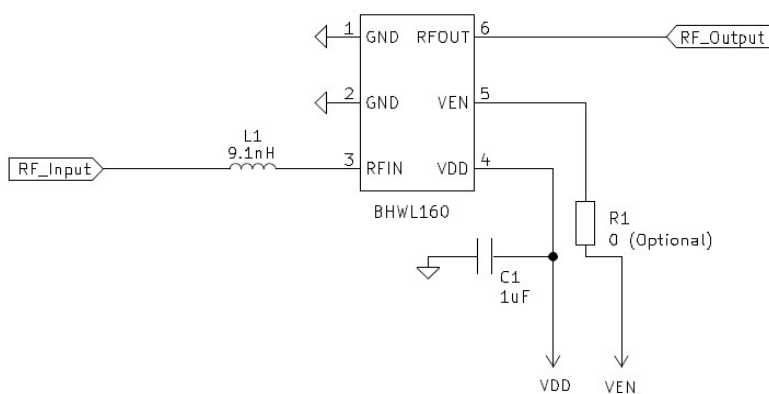



Wideband 0.6-2GHz GaAs Low Noise Amplifier

RF Characteristics (GNSS High-Band)

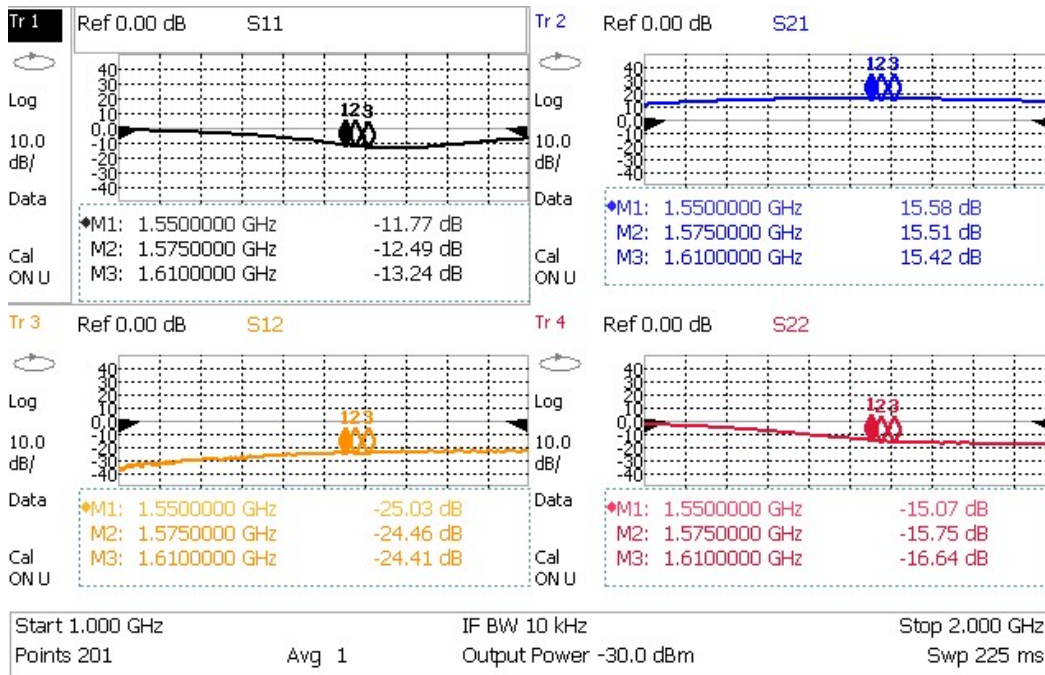

Typical Small-Signal S-Parameters at Vdd=Ven=3.3V, Pin=-30dBm

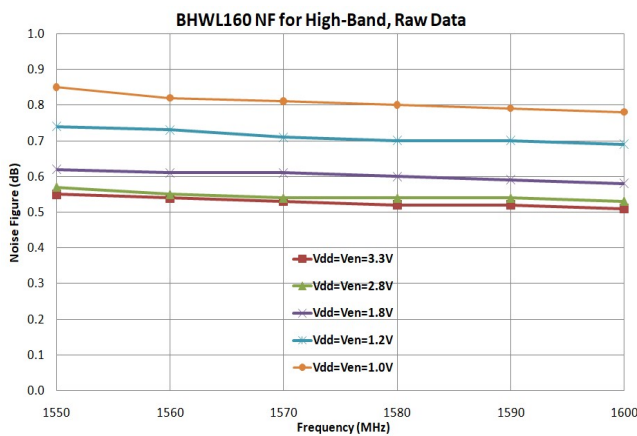

Typical Noise Figure vs Frequency and Vdd/Ven

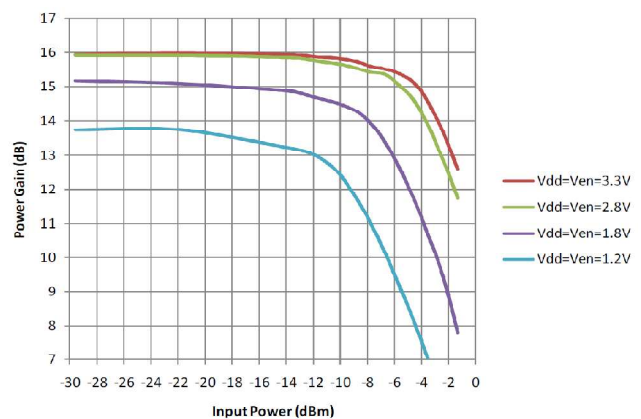

Typical Power Gain vs Pin & Vdd/Ven at 1575MHz



Wideband 0.6-2GHz GaAs Low Noise Amplifier

Electrical Specifications (GNSS Low-Band)*

Parameter	Condition	Specification			Unit
		Min.	Typ.	Max.	
Operating Frequency		1164	1176	1300	MHz
Operating Voltage		1.2	3.3	3.6	V
Quiescent Current	VDD=VEN=3.3V, No RF Input	3.7	6	8	mA
Shutdown Current	VDD=3.3V, VEN=0		0.3		uA
Small-Signal Gain	Pin=-30dBm		16		dB
Noise Figure**			0.9		dB
Input Return Loss			10		dBm
Output Return Loss			12		dB
Isolation			26		dB
Input P1dB	At VDD=VEN=3.3V		-7		dBm
IIP3	f1/f2=1176/1177MHz, -30dBm per Tone, 3.3V		+1		dBm

*As measured on BHWL160 EVB with L1=12nH, L2=8.2nH, L3=9.1nH (Murata LQW15 Series inductors), VDD=VEN=3.3V.

**For best NF the full-band matching network on page 3 is recommended, with slightly compromised S11 in L5 band.

Application Schematic and Evaluation Board (GNSS Low-Band)

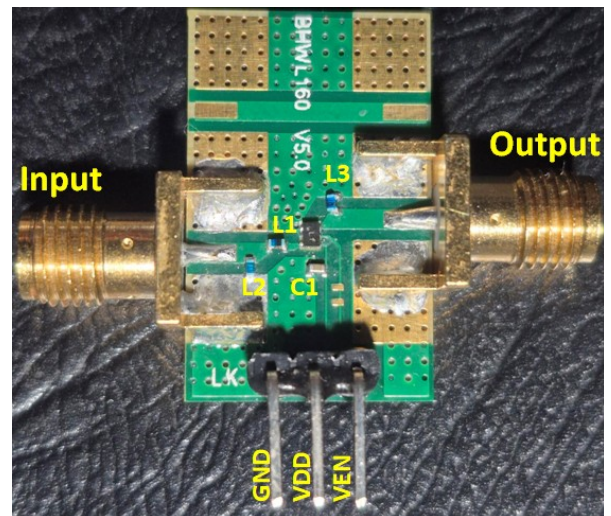
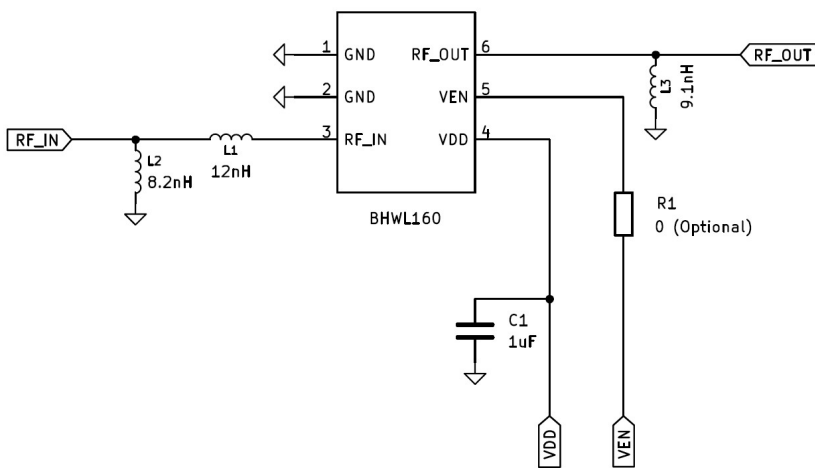



Wideband 0.6-2GHz GaAs Low Noise Amplifier

RF Characteristics (GNSS Low-Band)

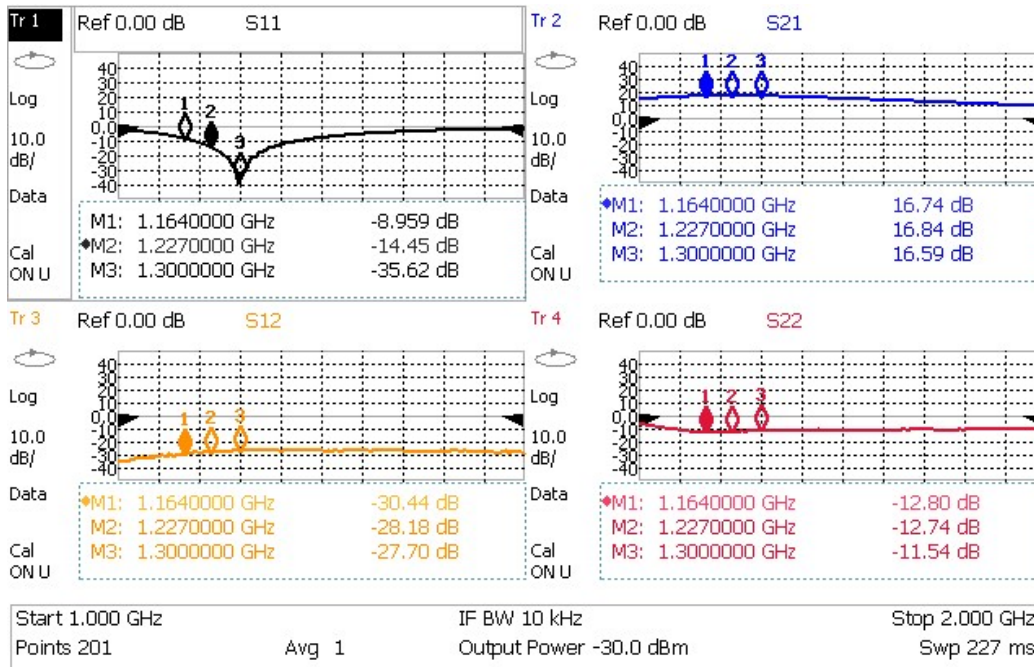

Typical Small-Signal S-Parameters at Vdd=Ven=3.3V, Pin=-30dBm

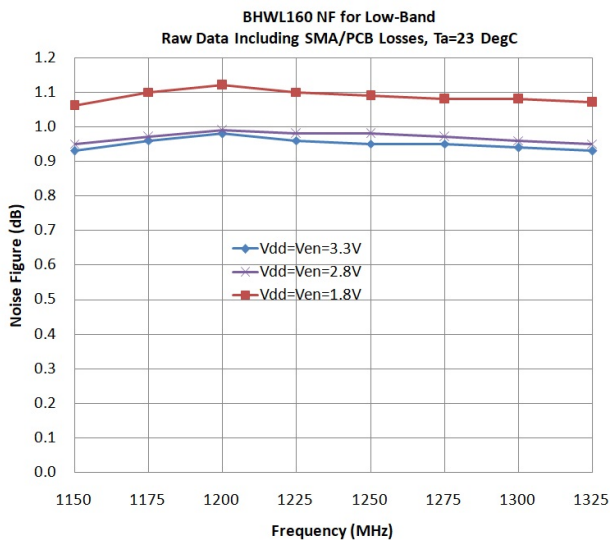

Typical Noise Figure vs Frequency and Vdd/Ven

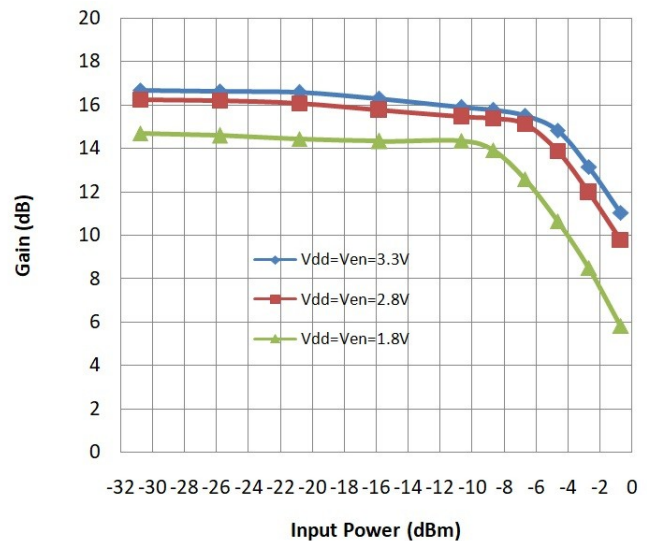

Typical Power Gain vs Pin & Vdd/Ven at 1176MHz



Wideband 0.6-2GHz GaAs Low Noise Amplifier

Package Drawing and Dimensions

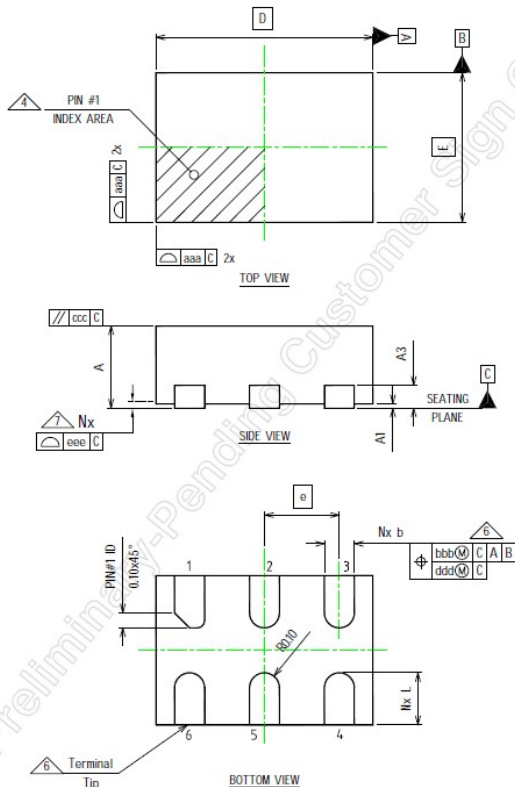

Dimension Table				
Thickness Symbol	UT			NOTE
	MINIMUM	NOMINAL	MAXIMUM	
A	0.51	0.55	0.60	
A1	0.00	0.02	0.05	
A3	---	0.15 Ref	---	
b	0.15	0.20	0.25	6
D	1.45 BSC			
E	1.00 BSC			
e	0.50 BSC			
L	0.25	0.35	0.45	
aaa	0.05			
bbb	0.10			
ccc	0.10			
ddd	0.05			
eee	0.08			
N	6			3
ND	3			5
NOTES	1, 2			
LF PART NO.	442520			
LF DWG. NO.	CARSEM-MHT-027 Rev. A			

Recommended Reflow Soldering Profile

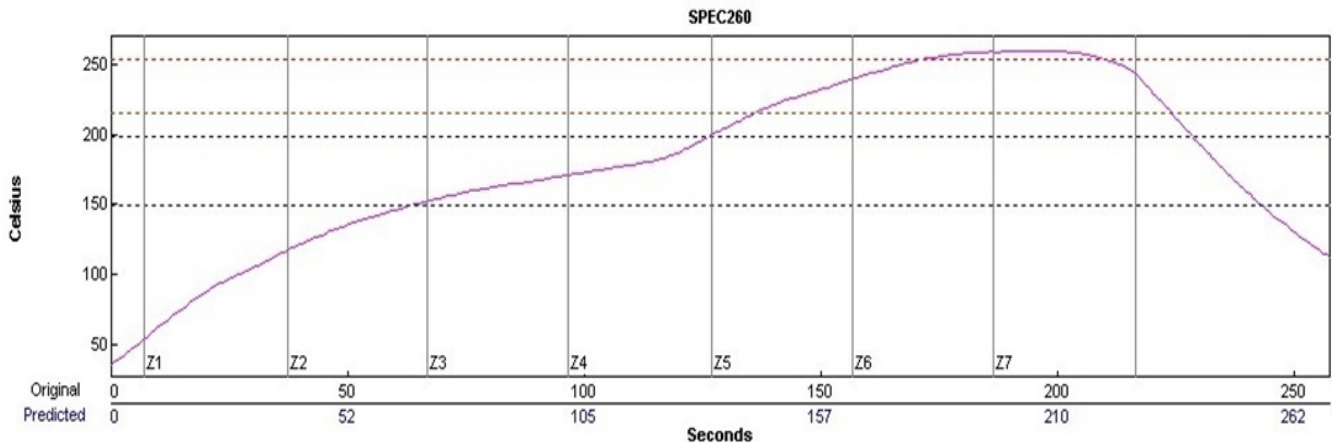



Wideband 0.6-2GHz GaAs Low Noise Amplifier

Package Marking and Date Code Information

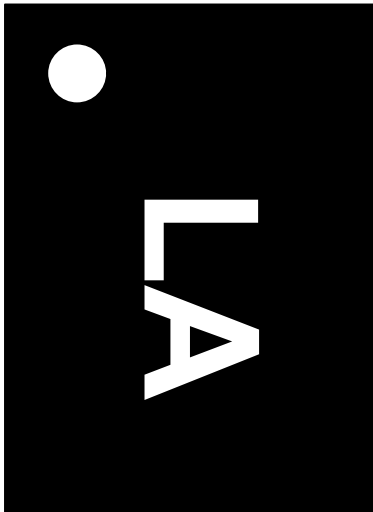

← Pin 1 Indicator

← Product Code for BHWL160 (Fixed)

← Date Code: See Date Code Table

BHWL160 Datecode Table

Year	Jan.	Feb.	March	April	May	June	July	August	Sept.	Oct.	Nov.	Dec.
2021	a	b	c	d	e	f	g	h	i	j	k	m
2022	n	p	q	r	s	t	u	v	w	x	y	z
2023	A	B	C	D	E	F	G	H	I	J	K	M
2024	N	P	Q	R	S	T	U	V	W	X	Y	Z
2025	a	b	c	d	e	f	g	h	i	j	k	m
2026	n	p	q	r	s	t	u	v	w	x	y	z
2027	A	B	C	D	E	F	G	H	I	J	K	M
2028	N	P	Q	R	S	T	U	V	W	X	Y	Z