



## Wideband 0.8-2.5GHz GaAs Linear Power Amplifier

### Description

BHWA251 is a wideband, high-efficiency linear power amplifier designed in advanced GaAs/InGaP process which can be tuned for operation from 800MHz to 2.5GHz. For 2.4GHz Wi-Fi, it provides up to +18/+20dBm linear output power for IEEE 802.11n/g at 3.3/5V. At UHF 915MHz, it delivers +25/+27.5dBm saturated power at 3.3/5V. It has full on-chip input matching (2.4GHz), active bias circuits, ESD protection at all pins, and requires simple output matching. The device is housed in an ultra-compact, 6-Lead DFN (Dual Flat No-Lead) package.

### Key Features

- Advanced GaAs/InGaP HBT Process
- 0.8-2.5GHz Operation Frequency Range
- Fully Matched Input Port (2.4GHz Band)
- Small-Signal Gain: 15dB at 2.4GHz (3.3V)
- Low Quiescent Current: 75mA or Less
- OP1dB: +23/+25.5dBm at 3.3/5V, 2.45GHz
- Saturated Power: +27.5dBm at 915MHz (5V)
- Ultra-Small 1.5x1.5mm DFN Package

### Key Applications

- IEEE 802.11 WLAN Systems
- Wi-Fi Modules
- Wireless Audio/Video
- Remote Control
- ZigBee/Thread/Matter Power Booster
- Sub-GHz NB-IoT, LoRa, SigFox, Z-Wave, RFID
- Generic UHF/2.4GHz Radio Designs

### Functional Block and Package Information

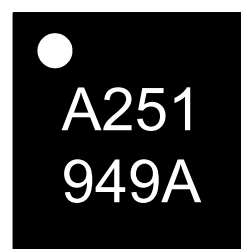
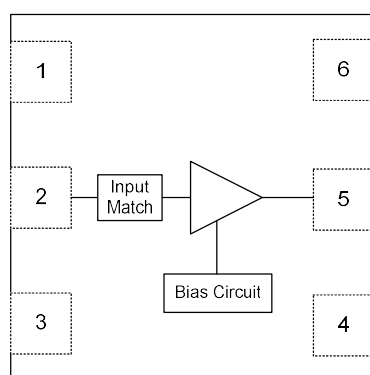

1.5x1.5x0.55mm 6L DFN



## Wideband 0.8-2.5GHz GaAs Linear Power Amplifier

### Pin Assignment and Pin Description

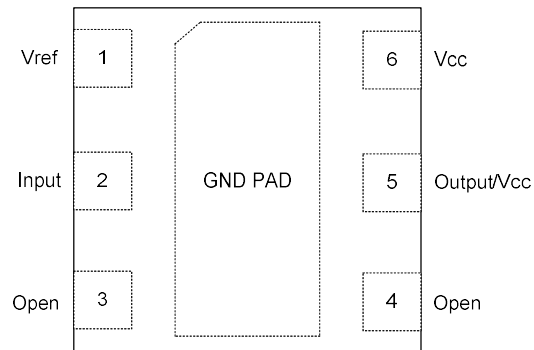

(Top "See-Through" View)

Pin Number	Pin Name	Description
1	Vref	Bias Control Voltage
2	Input	RF Input to the PA
3, 4	Open	These pins must be kept open in PCB layout
5	Output/Vcc	RF Output and DC Supply Voltage for the PA
6	Vcc	DC Supply Voltage for the PA Bias Circuit

### Absolute Maximum Ratings

Parameter	Rating	Unit
Maximum Supply Voltage	5.5	V
Maximum Bias Voltage	3.6	V
Maximum Supply Current	200	mA
Maximum Input Power	+10	dBm
Junction Temperature	+150	°C
Operation Temperature	-40 to +85	°C
Storage Temperature	-40 to +150	°C
Moisture Sensitivity Level	MSL1	

Note: Do not exceed any single or combination of the above parameters. Sustained operation at or above the Absolute Maximum Ratings may result in permanent damage to the device. Maximum Input Power Rating assumes 50-Ohm load impedance.



# Wideband 0.8-2.5GHz GaAs Linear Power Amplifier

## Electrical Specifications (2.4GHz Band) \*

Parameter	Condition	Specification			Unit
		Min.	Typ.	Max.	
Operating Frequency		2.4		2.5	GHz
Operation Supply Voltage		3	3.3	5	V
Quiescent Current	Vcc=Vref=3.3V, No RF		75		mA
Bias Control Current	Vcc=Vref=3.3V		2.2		mA
Small-Signal Gain	At 2.45GHz		15		dB
Linear Output Power 1	EVM=-25dB, 64QAM/54Mbps		+18		dBm
Linear Output Power 2	802.11b Mask Compliance		+23		dBm
Total Current	Pout=+18dBm		95		mA
Saturated Output Power	At 2.45GHz		+24		dBm
Output P1dB	At 2.45GHz		+23		dBm
2 <sup>nd</sup> -Order Harmonic	At P1dB=+23dBm		-43		dBc
3 <sup>rd</sup> -Order Harmonic	At P1dB=+23dBm		-37		dBc
Input Return Loss		10	12		dB
Output Return Loss		10	15		dB

\*Refer to BHWA251 Application Note for additional test data in details.

## Application Schematic (2.4GHz Band)

(Refer to BHWA251 Application Note for Details)

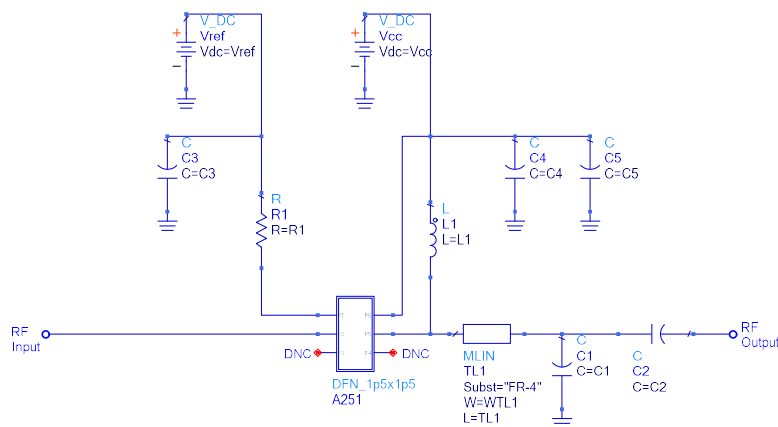

Note: Pin 3 and 4 must be kept as Open in PCB Layout.



# Wideband 0.8-2.5GHz GaAs Linear Power Amplifier

## Electrical Specifications (UHF 900MHz Band)\*

Parameter	Condition	Specification			Unit
		Min.	Typ.	Max.	
Operating Frequency		900	915	930	MHz
Operation Supply Voltage		4.75	5	5.25	V
Quiescent Current	Vcc=5V, Vref=3.3V, No RF		120		mA
Bias Control Current	Vcc=5V, Vref=3.3V		5		mA
Small-Signal Gain	At 915MHz		10		dB
Saturated Output Power	At 915MHz		+27.5		dBm
2 <sup>nd</sup> -Order Harmonic	At Pout=+27dBm		-26		dBc
3 <sup>rd</sup> -Order Harmonic	At Pout=+27dBm		-37		dBc
Output P1dB	At 915MHz		+25		dBm
Total Current	At P1dB=+25dBm		210		mA
Input Return Loss		10	15		dB
Output Return Loss		10	12		dB

\*Refer to BHW AppNote #004 for additional test data in details.

## Application Schematic (UHF 900MHz Band)

(Refer to BHW AppNote #004 for Details)

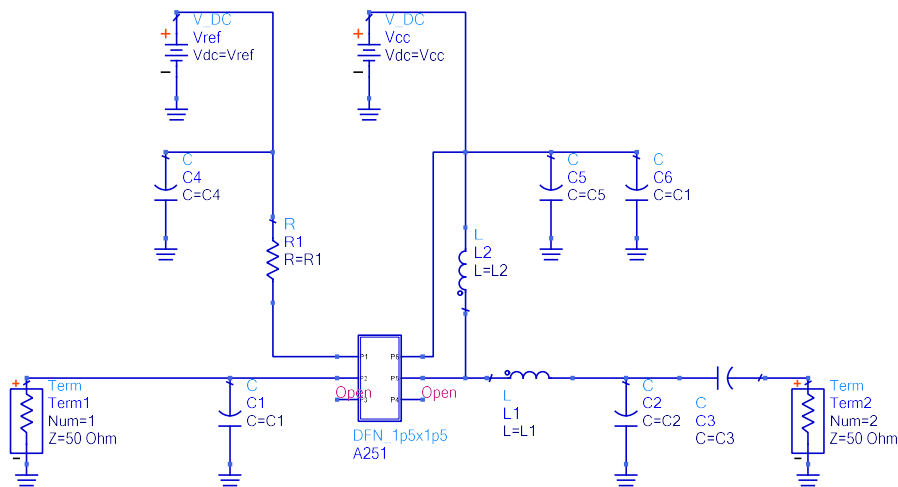

Note: Pin 3 and 4 must be kept as Open in PCB Layout.



# Wideband 0.8-2.5GHz GaAs Linear Power Amplifier

## Package Drawing and Dimensions

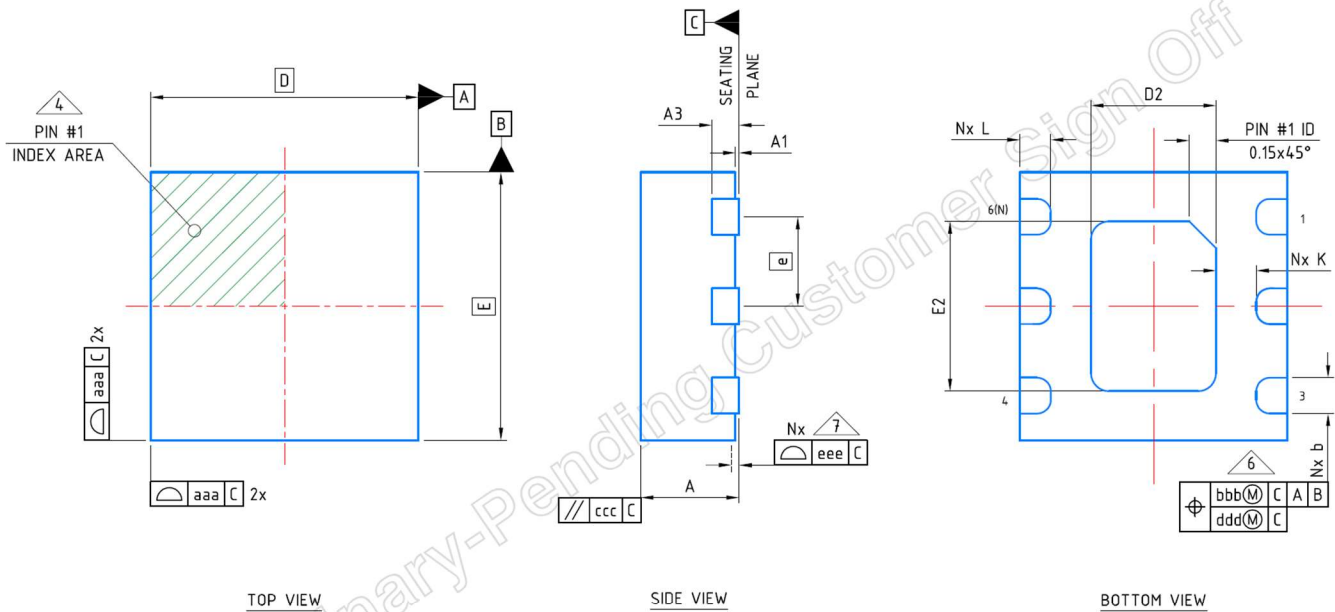

Dimension Table				
Thickness Symbol	UT			NOTE
	MINIMUM	NOMINAL	MAXIMUM	
A	0.51	0.55	0.60	
A1	0.00	0.02	0.05	
A3	---	0.15 Ref	---	
b	0.15	0.20	0.25	6
D	1.50 BSC			
E	1.50 BSC			
e	0.50 BSC			
D2	0.55	0.70	0.80	
E2	0.80	0.95	1.05	
K	0.15	---	---	
L	0.125	0.175	0.225	
aaa	0.05			
bbb	0.10			
ccc	0.10			
ddd	0.05			
eee	0.08			
N	6			3
NE	3			5
NOTES	1, 2			
LF PART NO.	443896			
LF DWG. NO.	CARSEM-HDS-043	Rev. A		

NOTE:

1. Dimensioning and tolerancing conform to ASME Y14.5-2009.
2. All dimensions are in millimeters.
3. N is the total number of terminals.
4. The location of the marked terminal #1 identifier is within the hatched area.
5. NE refers to the maximum number of terminals on E side.
6. Dimension b applies to the metallized terminal. If the terminal has a radius on the end of it, dimension b should not be measured in that radius area.
7. Coplanarity applies to the terminals and all other bottom surface metalization.



## Wideband 0.8-2.5GHz GaAs Linear Power Amplifier

### Package Marking



← Line 1: Pin 1 Indicator

← Line 2: Part Number, A251

← Line 3: Datecode, YWWA

### Date Code Description

Y: Year Code (e.g, 9 for 2019)

WW: Working Week (01~52)

A: Revision Code (Default=A)