



Broadband 0.1 - 6GHz 2-in-1 Cascadable Power Amplifier

Description

BHWA350 is a general-purpose power amplifier with broadband operation from sub-GHz to 6 GHz. It consists of two fully matched amplifiers operated at 3.3V and 5V, respectively, that can be used either independently or as a cascaded amplifier chain to achieve higher gain. The two amplifiers are housed in a super compact, 1.5x1.5mm 6-Lead DFN (Dual Flat No-Lead) package.

Key Features

- Advanced GaAs HBT Process
- Fully Matched Input/Output Ports
- Broadband 0.1 - 6GHz Operation or Beyond
- Gain: 18/16/10dB at 0.75/2.45/5.8GHz
- Psat: 14/13dBm at 2.45/5.8GHz (3.3V)
- Psat: 19/18dBm at 2.45/5.8GHz (5V)
- Low Quiescent Current 30/47mA at 3.3/5V
- Integrated ESD Protection for 1KV HBM
- Ultra-Small 1.5x1.5mm DFN Package

Key Applications

- VHF/UHF/2.4/5.8GHz Wireless Audio
- ZigBee/Thread/Matter Power Boosters
- 5-6GHz Wi-Fi Drivers or Power Boosters
- Small Cells and Cellular Repeaters
- Linear Driver for High-PAPR Waveforms such as OFDM, WCDMA, LTE/5G
- Generic Driver Amplifier from VHF to C-Band

Functional Block and Package Information

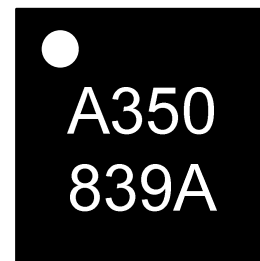
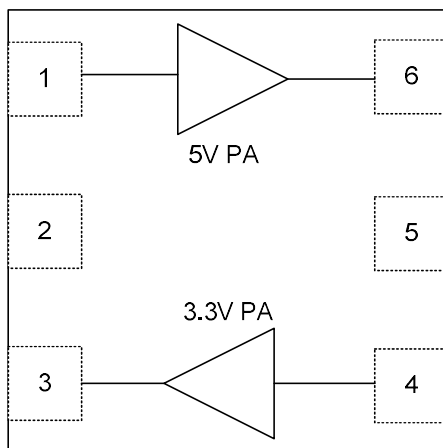

1.5x1.5x0.55mm 6L DFN



Broadband 0.1 - 6GHz 2-in-1 Cascadable Power Amplifier

Pin Assignment and Pin Description

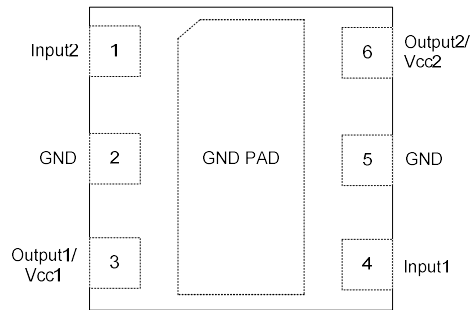

(Top “See-Through” View)

Pin Number	Pin Name	Description
1	Input2	RF Input of 5V PA
2,5	GND	Ground
3	Output1/Vcc1	RF Output/Vcc of 3.3V PA
4	Input1	RF Input of 3.3V
6	Output2/Vcc2	RF Output/Vcc of 5V PA

Absolute Maximum Ratings

Parameter		Rating	Unit
Maximum Voltage	3.3V PA	3.6	V
	5V PA	5.25	V
Maximum Current	3.3V PA	50	mA
	5V PA	80	mA
Maximum Input Power		+10	dBm
Junction Temperature		+150	°C
Operation Temperature		-40 to +85	°C
Storage Temperature		-40 to +150	°C
Moisture Sensitivity Level		MSL1	

Note: Do not exceed any single or combination of the above parameters. Sustained operation at or above the Absolute Maximum Ratings may result in permanent damage to the device. Maximum Input Power Rating assumes 50-Ohm load impedance.



Broadband 0.1 - 6GHz 2-in-1 Cascadable Power Amplifier

Electrical Specifications (3.3V PA)

Parameter	Condition	Specification			Unit
		Min.	Typ.	Max.	
Operating Voltage		3.15	3.30	3.45	V
Quiescent Current			30		mA
Small-Signal Gain	2.45GHz		16		dB
	5.8GHz		12		dB
Saturated Output Power	2.45GHz		14		dBm
	5.8GHz		13		dBm
Input Return Loss	2.45GHz		13		dB
	5.8GHz		14		dB
Output Return Loss	2.45GHz		13		dB
	5.8GHz		7		dB

Application Schematic (3.3V PA)

(Refer to BHWA350 Application Note for Details)

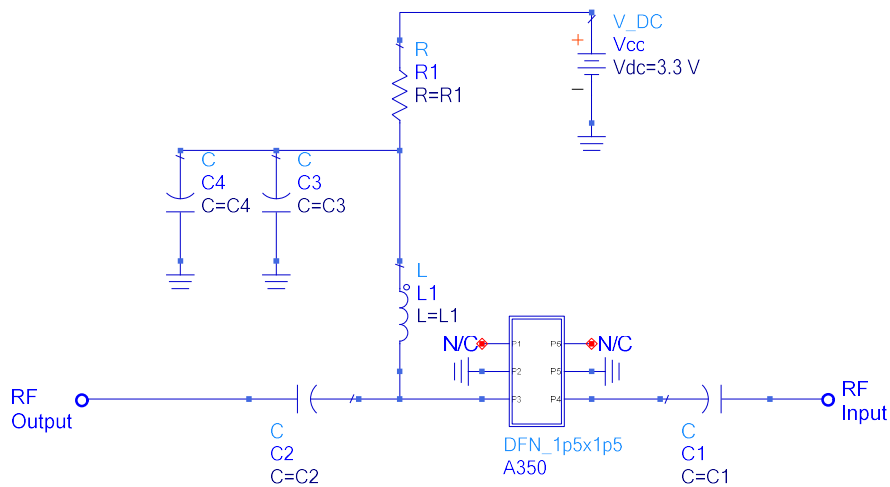



Broadband 0.1 - 6GHz 2-in-1 Cascadable Power Amplifier

Electrical Specifications (5V PA)

Parameter	Condition	Specification			Unit
		Min.	Typ.	Max.	
Operating Voltage		4.75	5.0	5.25	V
Quiescent Current			47*		mA
Small-Signal Gain	2.45GHz		16		dB
	5.8GHz		10		dB
Saturated Output Power	2.45GHz		19		dBm
	5.8GHz		18		dBm
Input Return Loss	2.45GHz		15		dB
	5.8GHz		15		dB
Output Return Loss	2.45GHz		13		dB
	5.8GHz		8		dB

*With 3-Ohm Bias Resistor.

Application Schematic (5V PA)

(Refer to BHWA350 Application Note for Details)

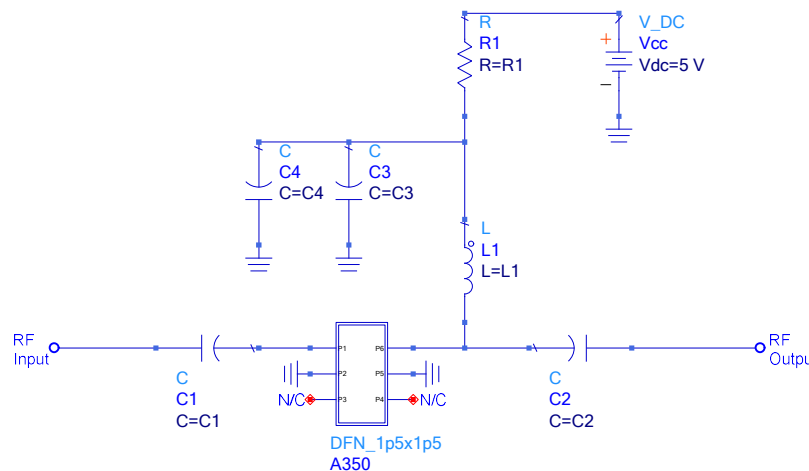



Broadband 0.1 - 6GHz 2-in-1 Cascadable Power Amplifier

Electrical Specifications (5V/5V Cascade)

Parameter	Condition	Specification			Unit
		Min.	Typ.	Max.	
Operating Voltage		4.75	5.0	5.25	V
Quiescent Current			77*		mA
Small-Signal Gain	2.45GHz		32		dB
	5.8GHz		20		dB
Saturated Output Power	2.45GHz		19		dBm
	5.8GHz		18		dBm
Input Return Loss	2.45GHz		12		dB
	5.8GHz		10		dB
Output Return Loss	2.45GHz		15		dB
	5.8GHz		11		dB

*With 68-Ohm/3-Ohm Bias Resistors for 3.3V/5V PA, respectively. See BHWA350 AppNote for details.

Application Schematic (5V/5V Cascade)

(Refer to BHWA350 Application Note for Details)

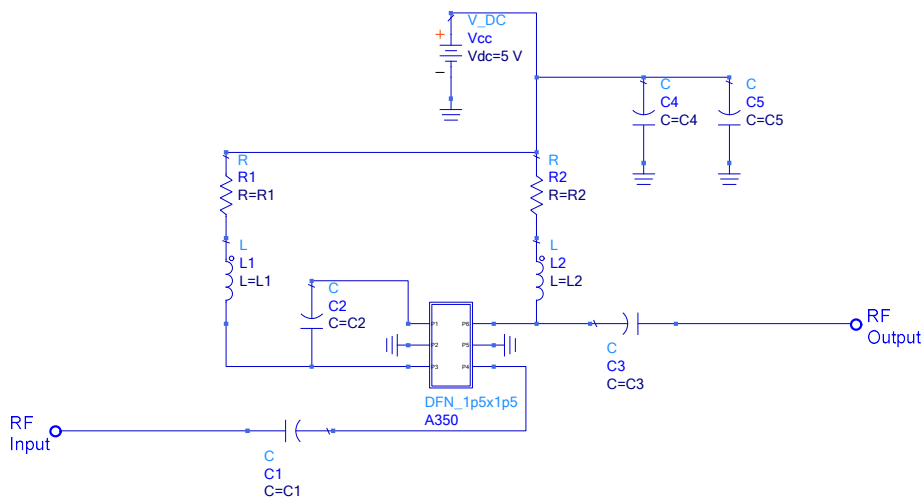



Broadband 0.1 - 6GHz 2-in-1 Cascadable Power Amplifier

Package Drawing and Dimensions

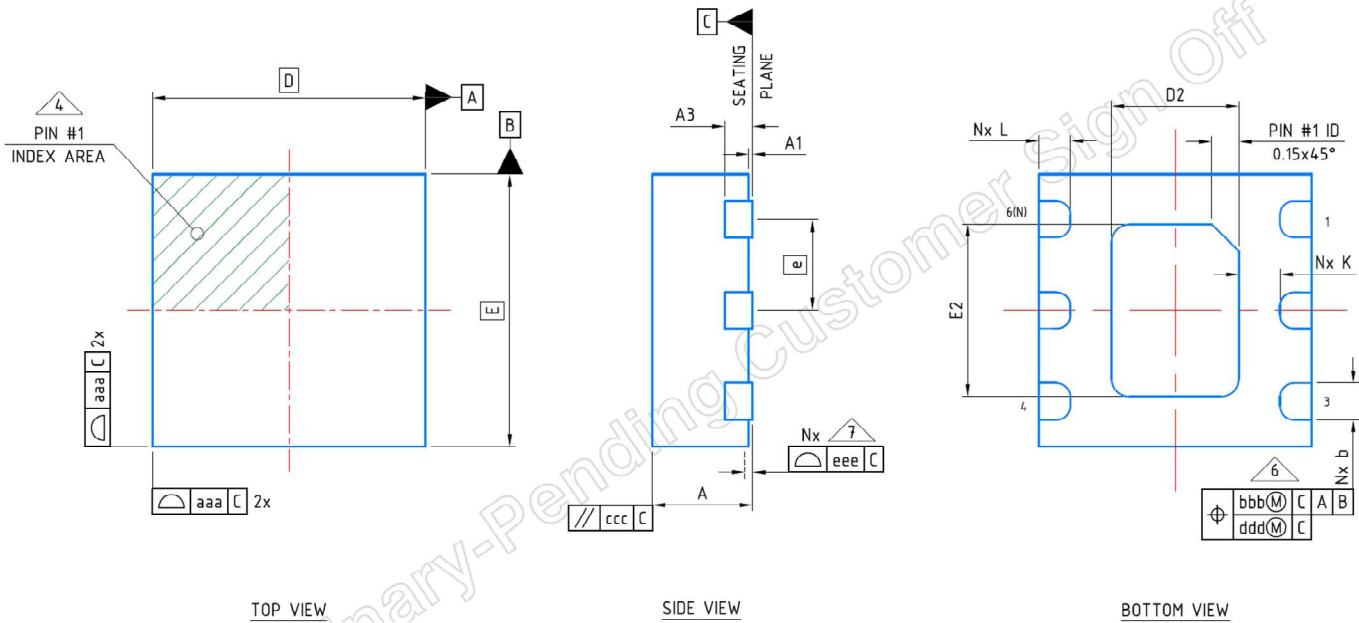

Dimension Table				
Thickness Symbol	UT			NOTE
	MINIMUM	NOMINAL	MAXIMUM	
A	0.51	0.55	0.60	
A1	0.00	0.02	0.05	
A3	---	0.15 Ref	---	
b	0.15	0.20	0.25	6
D	1.50 BSC			
E	1.50 BSC			
e	0.50 BSC			
D2	0.55	0.70	0.80	
E2	0.80	0.95	1.05	
K	0.15	---	---	
L	0.125	0.175	0.225	
aaa	0.05			
bbb	0.10			
ccc	0.10			
ddd	0.05			
eee	0.08			
N	6			3
NE	3			5
NOTES	1, 2			
LF PART NO.	443896			
LF DWG. NO.	CARSEM-HDS-043	Rev. A		

NOTE:

1. Dimensioning and tolerancing conform to ASME Y14.5-2009.
2. All dimensions are in millimeters.
3. N is the total number of terminals.
4. The location of the marked terminal #1 identifier is within the hatched area.
5. NE refers to the maximum number of terminals on E side.
6. Dimension b applies to the metalized terminal. If the terminal has a radius on the end of it, dimension b should not be measured in that radius area.
7. Coplanarity applies to the terminals and all other bottom surface metalization.



Broadband 0.1 - 6GHz 2-in-1 Cascadable Power Amplifier

Package Marking



← Line 1: Pin 1 Indicator

← Line 2: Part Number, A350

← Line 3: Datecode, YWWA

Date Code Description

Y: Year Code (e.g, 9 for 2019)

WW: Working Week (01~52)

A: Revision Code (Default=A)