



### 2.4GHz Two-Port Active Integrated Antenna with LNA and Switch

#### Description

BHWR250M is a complete RF Front-End solution from BHW's RF Active integrated Antenna (RFAiA™) product family. It integrates a low noise amplifier with ultra-low 1.7dB total noise figure and 13dB gain, a switch path with low loss of 0.7dB for optional insertion of a power amplifier for additional boost of transmit power, and a compact antenna with high efficiency and very stable VSWR under various PCB size and housing conditions, all into a compact 16x12mm design. BHWR250M can be easily surface-mounted to the main product board without requiring any additional impedance matching, resulting in significantly simplified RF design and shorter product development cycle.

#### Key Features

- 2.4-2.5GHz Operation Frequency Range
- Operating Voltage: 1.2~4.2V
- Rx Noise Figure: 1.7dB; Gain: 13dB
- LNA Current: 12mA at Vdd=3.3V (Adjustable)
- Tx Insertion Loss: 0.7dB
- Robust ESD Protection
- Minimal and Relaxed RF Design for Main PCB
- Compact 16x12mm footprint for SMT

#### Key Applications

- Bluetooth/BLE System
- IEEE 802.11 WLAN System
- Wi-Fi/BT Module
- Wireless Audio/Video
- Remote Control
- Generic 2.4GHz TDD Radio Designs

#### Functional Block and Product Information

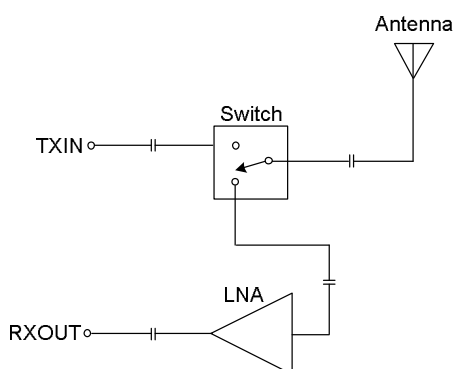

16x12x0.6mm PCB (with BHWM252)



## 2.4GHz Two-Port Active Integrated Antenna with LNA and Switch

### Pin Assignment and Pin Description

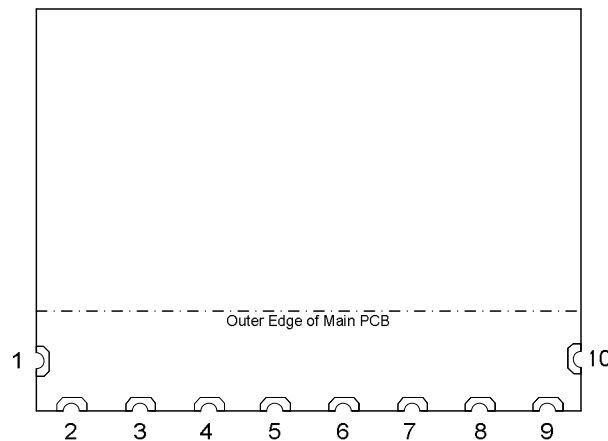

(Top "See-Through" View)

Pin Number	Pin Name	Description
5	RXOUT	Rx Output Port
6	VDD	DC Supply Voltage
7	CRX	Logic Control Voltage for Rx
8	CTX	Logic Control Voltage for Tx
9	TXIN	Tx Input Port
1,2,3,4,10	GND	Connect to GND on Main PCB

### Absolute Maximum Ratings

Parameter	Rating	Unit
Maximum VDD Supply Voltage	4.5	V
Maximum Control Voltage	3.6	V
Maximum VDD Supply Current	50	mA
Maximum Tx Input Power	+30	dBm
Junction Temperature	+150	°C
Operation Temperature	-40 to +85	°C
Storage Temperature	-40 to +150	°C
Moisture Sensitivity Level	MSL1	

Note: Do not exceed any single or combination of the above parameters. Sustained operation at or above the Absolute Maximum Ratings may result in permanent damage to the device. Maximum Input Power Rating assumes 50-Ohm load impedance.

**2.4GHz Two-Port Active Integrated Antenna with LNA and Switch****Electrical Specifications****Receive Mode: VDD=3.3V, CRX=3.3V, CTX=0**

Parameter	Condition	Specification			Unit
		Min.	Typ.	Max.	
Operating Frequency		2.4		2.5	GHz
Operating Voltage	VDD	1.2	3.3	3.6	V
Logic Control Voltage	For CRX=High	1.2	3.3	3.6	V
Quiescent Current*	VDD=CRX=3.3V, No RF Input		12		mA
Shutdown Current	VDD=3.3V, CRX=0			1	uA
Small-Signal Gain	Pin=-30dBm		13		dB
Noise Figure			1.7		dB
Input P1dB	VDD=3.3V		-1		dBm
Input VSWR**			2:1		dB

\*LNA current can be further reduced with an external resistor on CRX pin.

\*\*Measured data on a nominal EVB; Minor dependence on PCB design and proximity to plastic housing.

**Transmit Mode: VDD=3.3V, CTX=3.3V, CRX=0**

Parameter	Condition	Specification			Unit
		Min.	Typ.	Max.	
Operating Frequency		2.4		2.5	GHz
Operating Voltage	VDD	1.2	3.3	3.6	V
Logic Control Voltage	For CTX=High	1.2	3.3	3.6	V
Insertion Loss			0.7		dB
Input P1dB			+25		dBm
Input VSWR**			2:1		dB

\*Measured data on a nominal EVB; Minor dependence on PCB design and proximity to plastic housing.



## 2.4GHz Two-Port Active Integrated Antenna with LNA and Switch

### Transmit/Receive Control

CTX	CRX	Mode of Operation
0	0	All Off
1	0	Transmit (By-Pass)
0	1	Receive (LNA On)

### Application Schematic

(Refer to BHW AppNote #021 for Details)

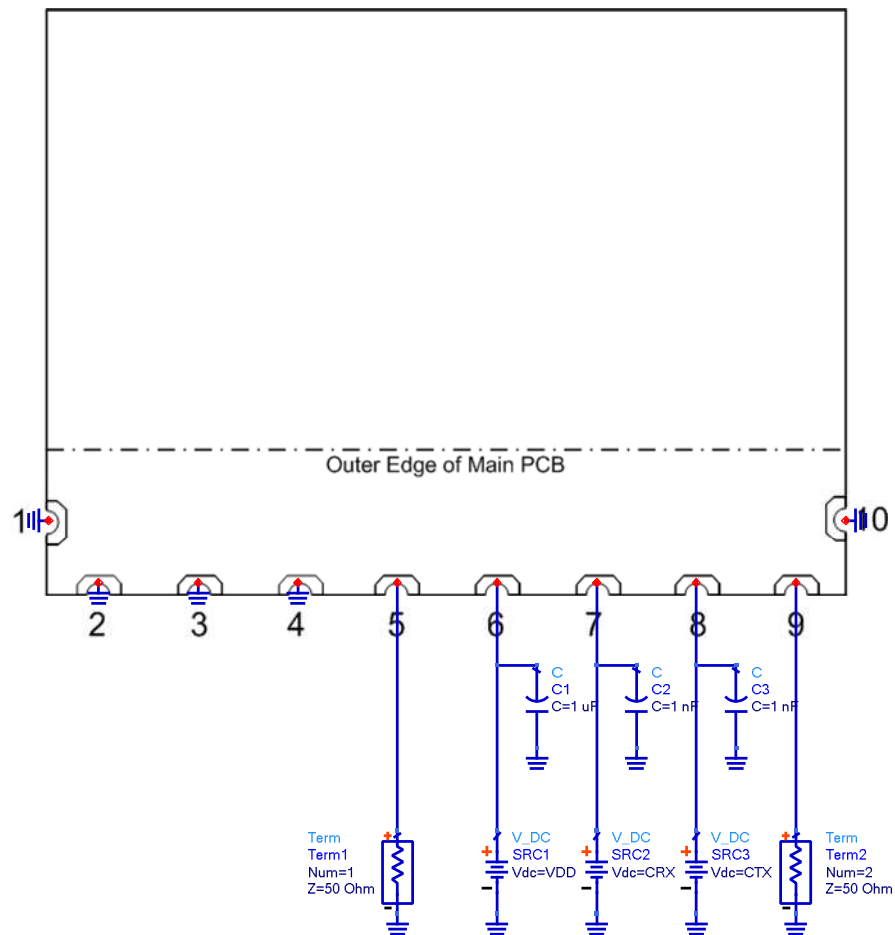



2.4GHz Two-Port Active Integrated Antenna with LNA and Switch

Mechanical Specifications

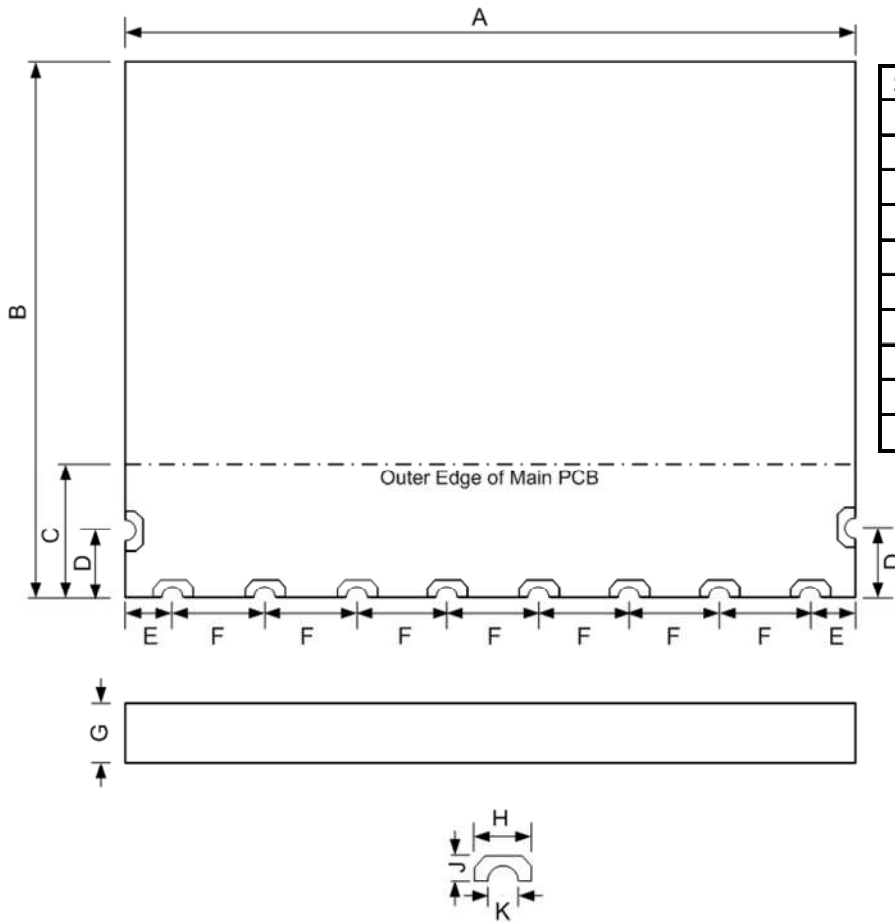

Symbol	Min. (mm)	Typ. (mm)	Max. (mm)
A	15.9	16	16.1
B	11.9	12	12.1
C	2.9	3	3.1
D	1.4	1.5	1.6
E	0.9	1	1.1
F	1.9	2	2.1
G	0.65	0.7	0.75
H	0.95	1	1.05
J	0.45	0.5	0.55
K	0.55	0.6	0.65