

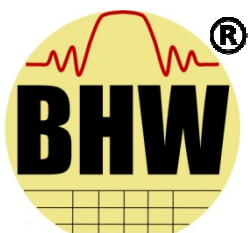

BHW Technologies (博泓微科技有限公司)



Advanced RF IC, Antenna, Filter, RF Front-End
and Wireless System Solutions

BHW Application Note #004

UHF 900MHz RF Front-End Solution Using BHWA251
Half-Watt PA and BHWL160 Sub-1dB-NF LNA

Rev. 1.5, 11/17/2020

www.bhw-tech.com

Background: Sub-GHz Wireless for IoT



Background & Challenges:

- Sub-GHz Frequencies such as the 868MHz and 915MHz ISM Bands Offer Unique Advantages for Wireless Communications, including Long Range, Low Power and Easy Penetration of Foliage and Obstacles
- Sub-GHz is Key Spectrum for LPWAN (Low-Power Wide-Area Network) Protocols, including LoRa, NB-IoT, SigFox and LTE-M, for Applications such as Asset Tracking, Smart Metering, Smart Cities and Home Automation
- Sub-GHz Frequencies are also Widely used in Other IoT Applications such as ZigBee, Z-Wave, RFID/RAIN and Many Proprietary Systems
- RF Front-Ends with Moderate Transmit Power (e.g. Half-Watt) and Best-Class Noise Figure (sub-1dB) Play a Critical Role for Successful Deployment of Long-Range Sub-GHz Products, but are Short in Supply and High in Cost Currently

BHW Solutions & Benefits:

- Using Advanced GaAs HBT & ED-PHEMT Technologies, BHW has Developed a Broad Portfolio of High-Performance, Cost-Effect RF Front-End ICs for Various Wireless Applications from 300MHz to 6GHz
- BHWA251 is a GaAs HBT PA with Half-Watt Output Power in a Very Compact 1.5x1.5mm DFN-6L Package
- BHWL160 is a GaAs ED-PHEMT LNA with Best-Class NF (sub-1dB) at Low Current, in Super-Compact 1.45x1mm DFN-6L Package
- BHWA350 is an Optional Low-Cost Broadband Gain Block with up to 35dB Gain to Allow Significant Back-Off of SoC Transmit Power and Greatly Reduce System Power Consumption

This AppNote Describes a FEM-Alternative of Complete Tx/Rx Front-End Solution that Offers Several Advantages such as High Performance, Better System Power Efficiency, Great Functional Flexibility, and Disruptive Cost Structure



NB-IoT™

LTE-M



sigfox



mioty
alliance



Proposed RF Front-End for UHF 860-930MHz

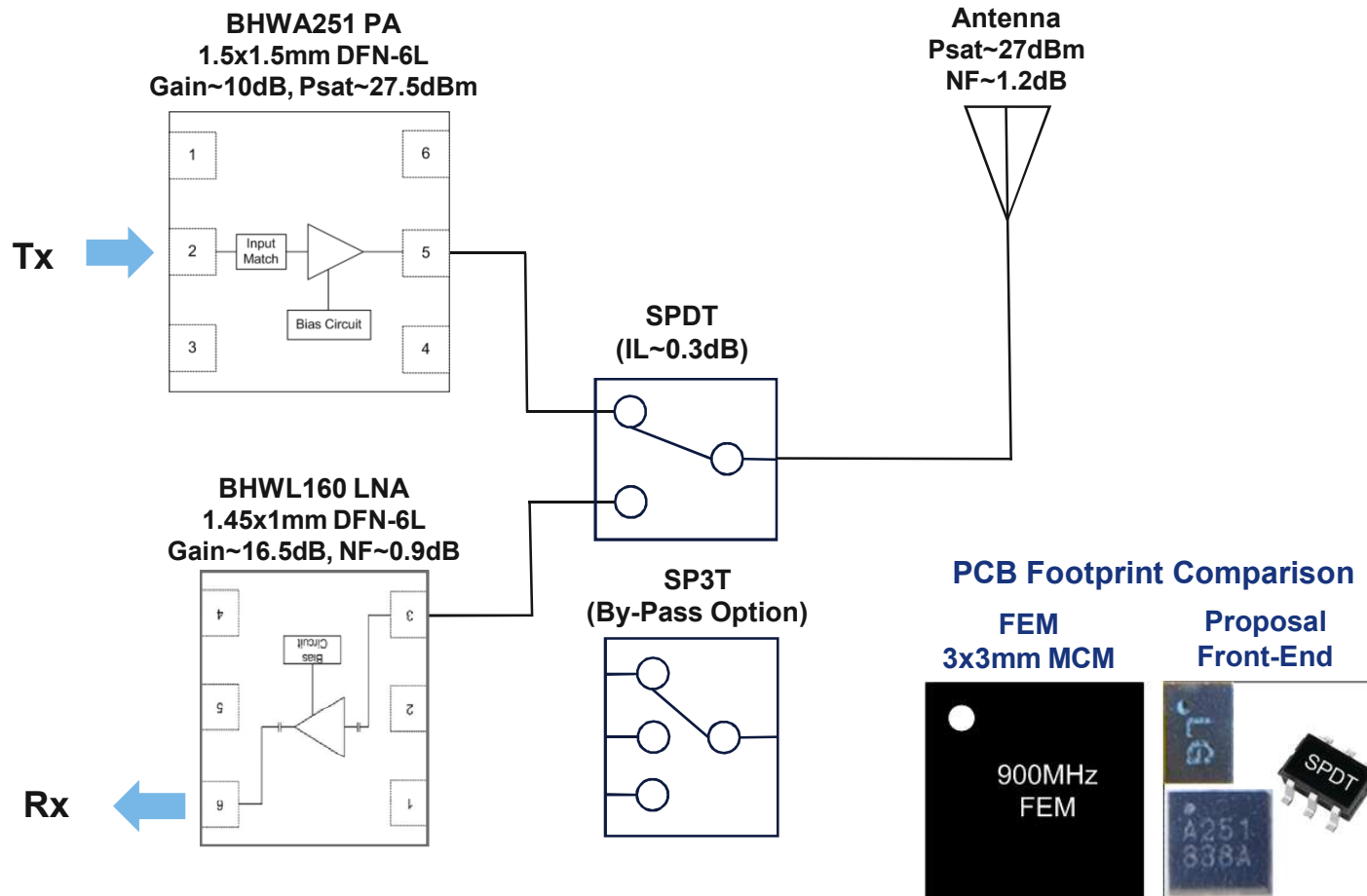

➤ Features and Benefits:

- Very Low-Cost Solution with Best-Class Performance (Fractional Price of FEM on the Market)
- BHWA251 High-Efficiency Half-Watt PA in 1.5x1.5mm DFN-6L
- BHWL160 Ultra-Compact LNA in 1.45x1mm DFN-6L with Sub-1dB NF
- Greatest Design Flexibility: Optional 3rd-Party SPDT/SP3T Provides Optimal Design to Meet Specific System Requirements
- Significant Improvement in Wireless Range (2x or more) at Reduced Total System Power Consumption

Proposed RF Front-End for UHF 860-930MHz



Application Schematic

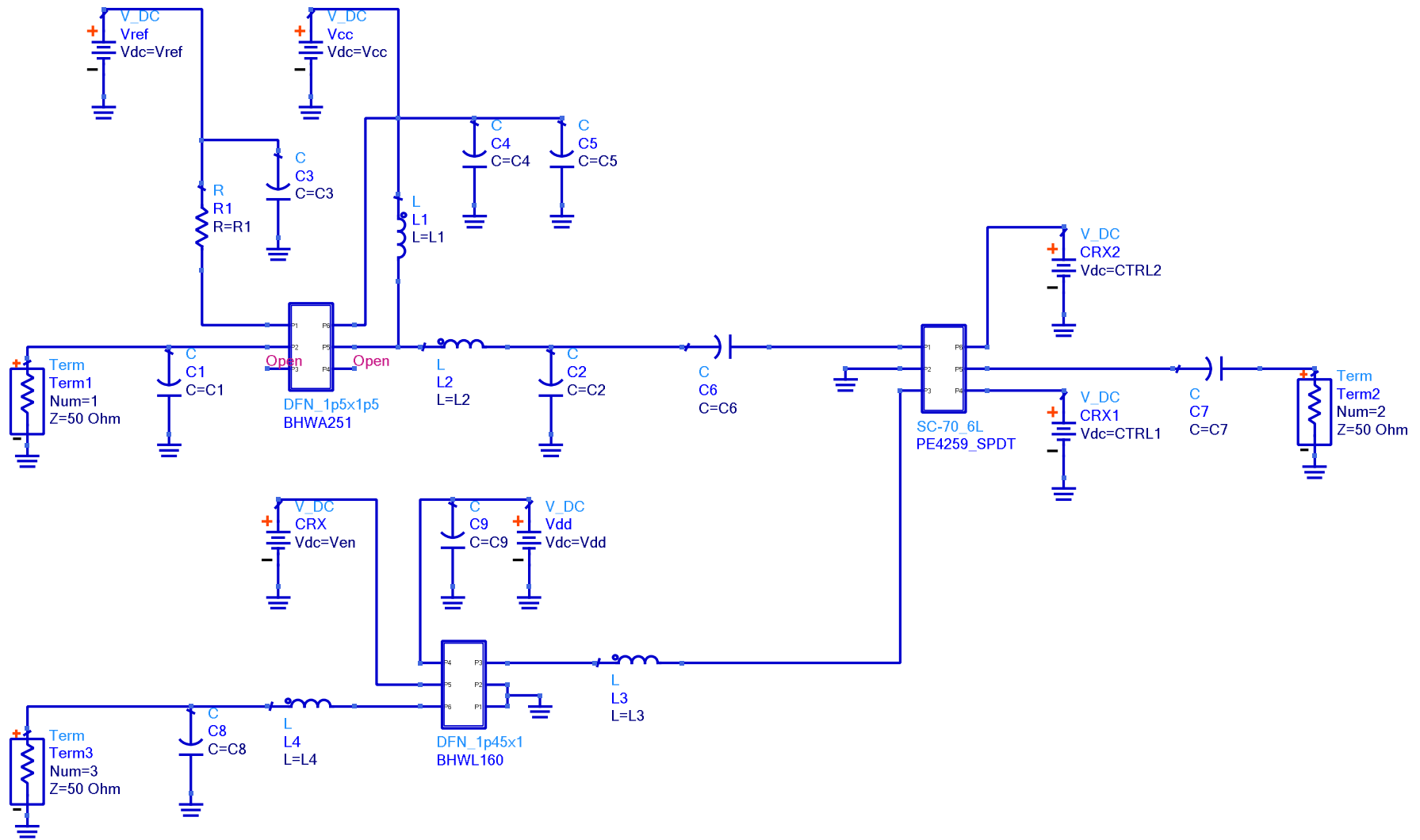

BHW RF Front-End AppNote Library



For further information, please email to support@bhwtechnologies.com, or contact your local BHW Sales Rep or Distributor. We will send you the complete AppNote as well as additional related information.

In addition to standard datasheets and EVB/BOM info, BHW publishes an AppNote series that address various topics on RF front-end design and performance over a wide frequency range from 300MHz to 6GHz, as an effort to assist customers in developing cutting-edge, cost-competitive products:

- BHW AppNote #001 - Cross-Over Cascade of BHWM253 to Boost Tx Power and Rx Sensitivity of BLE and 2.4GHz IoT
- BHW AppNote #002 - Accurate Benchmark of GNSS CN0 Using the Power-Splitter Method
- BHW AppNote #003 - Boosting Wi-Fi Tx Power and Rx Sensitivity with BHWA251 and BHWM252
- BHW AppNote #004 - UHF 900MHz RF Front-End Solution Using BHWA251 Half-Watt PA and BHWL160 Sub-1dB-NF LNA
- BHW AppNote #005 - Sub-1GHz Applications of BHWA350 2-in-1 Wideband Fully Matched Amplifier
- BHW AppNote #006 - Low-Noise High-IIP3 LNB Architecture for Dual-Band High-Precision GNSS Using Cascade of BHWL160
- BHW AppNote #007 - UWB RF Front-End Solution Using BHWA350 and BHWM552
- BHW AppNote #008 - High-Power 5.8GHz RF Front-End Solution Using BHWA555 and BHWM552 for ETC, V2X and Wireless Video
- BHW AppNote #009 - 5.8GHz RF Front-End Using BHWA350 and BHWM552 for Wireless Audio
- BHW AppNote #010 - Multi-Constellation GNSS Active Antenna Using BHWL161 Cascade and Single-Fed Dual-Band Antenna
- BHW AppNote #011 - BHWL161 Super-Compact Low-Power Low Noise Amplifier for Range Extension of 2.4GHz BLE, RC and IoT
- BHW AppNote #012 - Enabling Cost-Effective High-Precision GNSS Using BHWL160 and Linear-Polarization PCB Antenna
- BHW AppNote #013 - Enabling Long-Range BLE AoA&AoD for High-Precision Indoor Positioning with BHW GaAs RF Front-End ICs
- BHW AppNote #014 - Designing Ultra Low-Power High-Performance GNSS Products Using BHWL160 GaAs PHEMT LNA
- BHW AppNote #015 - BHWL161 GNSS Full-Band High-Performance LNA in Super-Compact 1x1mm DFN with Relaxed Pin Pitch
- BHW AppNote #016 - Improving GNSS NF Measurement Accuracy Using Broadband LNA BHWL161 as Pre-Amp
- BHW AppNote #017 - High-Efficiency, Low-NF 2.4GHz Front-End Solution for BLE & IoT Using BHWA251 and BHWM252
- BHW AppNote #018 - Optimizing BHWA555 Wideband One-Watt PA for Long-Range 5.8GHz Transmitter Applications
- BHW AppNote #019 - Miniature 2.4GHz RF Front-End with Integrated Chip Antenna and BHWM253 for TWS and IoT
- BHW AppNote #020 - Doubling the Range for BLE Music Streaming with BHW R250L Active Integrated Antenna (AIA)